

Installation and Commissioning Guide

iDirect Remote Satellite Routers

iDS Release 8.3

August 29, 2008



Copyright © 2008 VT iDirect, Inc. All rights reserved. Reproduction in whole or in part without permission is prohibited. Information contained herein is subject to change without notice. The specifications and information regarding the products in this document are subject to change without notice. All statements, information, and recommendations in this document are believed to be accurate, but are presented without warranty of any kind, express, or implied. Users must take full responsibility for their application of any products. Trademarks, brand names and products mentioned in this document are the property of their respective owners. All such references are used strictly in an editorial fashion with no intent to convey any affiliation with the name or the product's rightful owner.

Document Name: PROC_Remote Installation Guide iDS 8.3 Rev A_082908.pdf

Document Part Number: T0000151

Contents

About This Guide	ix
Purpose	ix
Intended Audience	ix
Contents Of This Guide	ix
Document Conventions	x
Related Documents	xi
Getting Help	xi
1 Getting Started	1
1.1 Required Equipment	1
1.2 When to Use This Guide	1
1.3 How to Use This Guide	2
2 Installing Software on your Laptop	3
2.1 Installing Software Downloaded from the Internet or CD	3
2.2 Components of the iSite Software and Remote Modem Images	3
3 Connecting to the Satellite Router	5
3.1 Access Your Satellite Router Using HyperTerminal	5
3.2 Telnet to the iDirect Application	8
3.3 Discovering the Satellite Router's IP Address and Application Version	9
3.4 Modify Your Laptop's IP Address and Subnet Mask	10

4	Downloading Packages to the Satellite Router	13
5	Downloading the Options File to the Satellite Router	21
6	Setting Up your Antenna	23
6.1	Select a Site for the Antenna	23
6.2	Assemble the Antenna	23
6.3	Align the Antenna toward the Spacecraft	23
7	Pointing the Antenna Using a Voltmeter	25
7.1	Prepare the Indoor Unit (IDU) and Outdoor Unit (ODU) for Pointing	25
7.2	Log in to Your Satellite Router	25
7.3	Calculate Polarization, Azimuth, and Elevation	26
7.4	Perform Pulse Width Modulation (PWM) Antenna Pointing	28
8	Tuning Antenna Pointing and Cross Polarization	33
8.1	Set up the Satellite Router for Cross Polarization	33
8.2	Set up iSite for Cross Polarization	33
8.3	Preparing for the Cross Polarization Test	34
8.4	Running the Cross Polarization Test	34
8.4.1	Adjusting Azimuth	34
8.4.2	Adjusting Elevation	35
8.4.3	Adjusting the Polarization	35
8.4.4	After the Cross Polarization Test	35
9	Establishing the 1 dB Compression Point	37
10	Recording Geo Location (Secure Mobile Remotes Only)	39
10.1	Set the Satellite Router's Geo Location	39
10.2	Verify the Satellite Router's Geo Location	40
11	Bringing the Satellite Router into the Network	41
11.1	iNFINITI Front Panel LEDs	42
11.2	Evolution e8350 Front Panel LEDs	43

12 Post Acquisition Activities	45
12.1 Network Help Desk Duties	45
12.2 Remote Installer Duties	46
13 Adjusting Power and Setting UCP Parameters	47
13.1 Set the Maximum Tx Power for a Remote	47
13.2 Set the Initial Tx Power for a Remote	49
13.3 Set the Clear Sky C/N Parameters for a Mesh Remote	52
Appendix A Loading Images Using the TFTP Server	55
Appendix B Pointing the Antenna Using Console Commands.	57
B.1 Performing Console Antenna Pointing	57
B.2 Modifying the Options File to Disable the Transmit PWM Voltage	57
B.3 Starting the Console Pointing	58
B.4 Using the DVM for Console Pointing	58
B.5 Final Adjustments	59
Appendix C Disabling the PWM Voltage in iBuilder	61
Appendix D Pinout for RJ-45 to DB-9 Adapter	63

List of Figures

Figure 1. HyperTerminal Connection Description Dialog Box	5
Figure 2. HyperTerminal Connect To Dialog Box	6
Figure 3. HyperTerminal COM1 Properties Dialog Box	6
Figure 4. Logging On to root Account During a Console Session	7
Figure 5. Telneting to iDirect Application During a Console Session	8
Figure 6. Logging On to Admin Account During a Console Session	8
Figure 7. Entering the <code>laninfo</code> Command	9
Figure 8. Entering the <code>version</code> Command	9
Figure 9. Local Area Connection Status Dialog Box	10
Figure 10. Local Area Connection Properties Dialog Box	10
Figure 11. Internet Protocol (TCP/IP) Dialog Box	11
Figure 12. iSite Welcome Screen	13
Figure 13. iSite Login Dialog Box	14
Figure 14. Download Package Dialog Box	15
Figure 15. Open Dialog Box with Images Folder	16
Figure 16. Remote Packages for Satellite Router Models	17
Figure 17. Download Package Dialog Box with Correct Selections	17
Figure 18. Download Package Dialog Box: Information Section	18
Figure 19. Remote Packages With Remote Image File Selected	18
Figure 20. Open Dialog Box with Remote Options File Selected	21
Figure 21. iSite Options File Download Confirmation Dialog Box	22
Figure 22. Resetting the Satellite Router After Download	22
Figure 23. Antenna Elevation Offset	24
Figure 24. iSite Login Dialog Box	26
Figure 25. iSite Antenna Pointing Dialog Box	27
Figure 26. Comparing Signal Strength	29
Figure 27. Locking on to a Carrier Stream	30
Figure 28. Cross Polarization Dialog Box	33
Figure 29. iDirect 3000 series Satellite Router Front Panel	41
Figure 30. Entering the <code>rmstat</code> Command	46
Figure 31. iBuilder Remote Information Tab: Setting Max Power	48
Figure 32. iMonitor Probe	49
Figure 33. iMonitor Change Remote Tx Power Dialog Box	49
Figure 34. iMonitor Remote Status Dialog Box	50
Figure 35. iBuilder Remote Information Tab: Transmit Properties Section	51
Figure 36. iMonitor Control Panel	52
Figure 37. iBuilder Remote Information Tab: Setting Clear Sky C/N	53
Figure 38. iBuilder Remote Information Tab: Disabling Tx PWM	62

List of Tables

Table 1. Remote Image Packages	16
Table 2. Signal Strength Ranges (PWM)	28
Table 3. iDirect iNFINITI LED Status	42
Table 4. iDirect Evolution e8350 LED Status	43
Table 5. Signal Strength Ranges (DVM).	58
Table 6. DB-9 to RJ-45 Adapter Pinout.	63



About This Guide

Purpose

This document provides detailed instructions for installing and commissioning iDirect Satellite Routers.

Intended Audience

This guide is written for iDirect installers and for other satellite technicians tasked with the installation and commissioning of iDirect iNFINITI or Evolution Satellite Routers.

Contents Of This Guide

This document contains the following major sections:

- [“Getting Started”](#)
- [“Installing Software on your Laptop”](#)
- [“Connecting to the Satellite Router”](#)
- [“Downloading Packages to the Satellite Router”](#)
- [“Downloading the Options File to the Satellite Router”](#)
- [“Setting Up your Antenna”](#)
- [“Pointing the Antenna Using a Voltmeter”](#)
- [“Tuning Antenna Pointing and Cross Polarization”](#)
- [“Establishing the 1 dB Compression Point”](#)
- [“Recording Geo Location \(Secure Mobile Remotes Only\)”](#)
- [“Bringing the Satellite Router into the Network”](#)
- [“Post Acquisition Activities”](#)
- [“Adjusting Power and Setting UCP Parameters”](#)
- [Appendix A, “Loading Images Using the TFTP Server”](#)
- [Appendix B, “Pointing the Antenna Using Console Commands”](#)
- [Appendix C, “Disabling the PWM Voltage in iBuilder”](#)
- [Appendix D, “Pinout for RJ-45 to DB-9 Adapter”](#)

Document Conventions

This section illustrates and describes the conventions used throughout the manual. Take a look now, before you begin using this manual, so that you'll know how to interpret the information presented.

Convention	Description	Example
Blue Courier font	Used when the user is required to enter a command at a command line prompt or in a console.	<code>[SWITCH_PORT_n] vid = vlan_id</code>
Courier font	Used when showing resulting output from a command that was entered at a command line or on a console.	Output similar to the following sample appears: [SECURITY] password = \$idi2\$/bFMhf\$5H8mYAaP1sTZ0m1Ny/dYyLaS40/ admin_password = \$idi2\$146rgm\$.KtDb4OH5CEBxzH6Ds2xM.ehHCH os_password = \$1\$UTKh0V\$cc/UfNThFmBI7sT.zYptQ0
Bold Trebuchet font	Used when the user is required to type information or values into a field within a windows-type interface software.	1. If you are adding a remote to an inroute group, right-click the Inroute Group and select Add Remote.
	Used when specifying names of commands, menus, folders, tabs, dialogs, list boxes, and options.	The Remote dialog box has a number of user-selectable tabs across the top. The Information Tab is visible when the dialog box opens.
Blue Trebuchet font	Used to show all hyperlinked text within a document.	For instructions on adding an iSCPC line card to the network tree and selecting a Hub RFT for the line card, see “Adding an iSCPC Line Card” on page 108.
Bold italic Trebuchet font	Used to emphasize information for the user, such as in notes.	Note: <i>Several remote model types can be configured as iSCPC remotes.</i>
Red italic Trebuchet font (or see table below)	Used when the user needs to <i>strictly</i> follow the instructions or have additional knowledge about a procedure or action.	WARNING! <i>The following procedure may cause a network outage.</i>

Related Documents

The following iDirect documents are available at <http://tac.idirect.net> and may also contain information relevant to this release. Please consult these documents for information about installing and using iDirect's satellite network software and equipment.

- *iDS Release Notes*
- *iDS Software Installation Guide or Network Upgrade Procedure Guide*
- *iDS iBuilder User Guide*
- *iDS iMonitor User Guide*
- *iDS Technical Reference Guide*
- *iDS Software Installation Survey*
- *iDirect Hub Readiness Checklist*
- *Teleport Design Considerations*
- *Hub Installation Guide*
- *iDirect Hub Installation As-Built Template*
- *iDirect Acceptance Test Plan*
- *iDS 8.3 Link Budget Analysis Guide*

Getting Help

The iDirect Technical Assistance Center (TAC) is available to help you 24 hours a day, 365 days a year. Software user guides, installation procedures, a FAQ page, and other documentation that supports our products are available on the TAC webpage. Please access our TAC webpage at: <http://tac.idirect.net>.

If you are unable to find the answers or information that you need, you can contact the TAC at (703) 648-8151.

If you are interested in purchasing iDirect products, please contact iDirect Corporate Sales by telephone or email.

Telephone: (703) 648-8000

Email: SALES@iDirect.net



1 Getting Started

This Installation and Commissioning Guide is intended to help you quickly install and commission iDirect Satellite Routers. The document applies to both iFINITI and Evolution series Satellite Routers.

iDirect Satellite Routers run the Linux operating system.

1.1 Required Equipment

You will need the following equipment and software to successfully commission the Satellite Router in the field:

- A console cable with DB9 adapter
- A crossover LAN cable
- A digital (or analog) voltmeter plus adaptor from voltmeter to IFL “F” connector
- A hand-held GPS unit or a map that shows your current geographic location coordinates
- A laptop (or PC) with:
 - Windows XP or Windows 2000, Service Pack 3
 - A minimum of 512 MB RAM
 - A minimum processor speed of 1 GHz
 - A minimum of 50 MB of free disk space
- The correct options file provided to you by your Service Provider.
- The correct remote application, firmware and board support packages provided to you by your Service Provider.

Note: *Direct recommends disabling the firewall on your laptop to ensure complete functionality.*

1.2 When to Use This Guide

Use this guide when first installing and commissioning an iDirect Satellite Router. Also, you must repeat the procedures in this manual if you move your iDirect Satellite Router from one established location to another.

Once you have successfully commissioned an iDirect Satellite Router at a specific location, it can be reset at any time. Resetting the router causes it to perform a self-test startup sequence and re-acquire the satellite network.

1.3 How to Use This Guide

This guide documents the step-by-step procedures required to commission and install your Satellite Router. The procedures appear in the order in which they should be performed. Therefore, be sure to perform the steps in this guide in the sequence in which they are presented.

2 Installing Software on your Laptop

These instructions guide you through the process of installing the iSite software and remote images onto your laptop or PC. The software may be downloaded from the TAC Web Page (<http://tac.idirect.net>) or it may be distributed to you on a CD.

2.1 Installing Software Downloaded from the Internet or CD

iSite software is usually distributed in a ZIP file format. After receiving the compressed archive file, *remote-version.zip*, copy it to a directory where you can uncompress the files. Be sure to store the files in a directory on your laptop that you can locate later.

1. Uncompress the files by using a utility that understands the .zip format.
2. If desired, create a shortcut to iSite.exe on the desktop or Windows taskbar. iSite is located in the iSite folder.
3. Run the iSite program wizard to install the software on your laptop.

2.2 Components of the iSite Software and Remote Modem Images

The Images for the iDirect Satellite Router and iSite software are bundled together in the download. This includes:

- The NMS iSite program and support files
- The iNFINITI Remote Modem application and image files (under Remote_iNFINITI)
- The iNFINITI 3xxx Remote Modem application and image files (under Remote_3xxx for iNFINITI 3100 series modems only)
- The “cumulative update” board support package for *all* iNFINITI Remote Modems (under Remote_3xxx and Remote_iNFINITI.)
- The Evolution e8350 Remote Modem application and image files (under Remote_Evolution)
- The Evolution e8350 Remote Modem board support package (BSP) (under Remote_Evolution)

A directory structure similar to the following will be created when you uncompress the files:

```
NetModem-<version>/
    iSite/
    Images/
        Remote_3XXX
        Remote_Evolution
        Remote_iNFINITI
```

where : *version* is the software version number in the form X_X_X.X.

Note: *iDS 8.3.x images are contained in folders where the version begins with the digits 8_3.*

3 Connecting to the Satellite Router

You can use any terminal emulator to connect to the Satellite Router console. The HyperTerminal application comes pre-installed on all Windows 2000 and XP machines. This section uses HyperTerminal to illustrate how to connect to your Satellite Router.

3.1 Access Your Satellite Router Using HyperTerminal

1. Connect the RJ-45 to DB-9 adapter to the COM1 port of your laptop.
2. Plug the other end of the cable into the Console port of the iDirect Satellite Router.
3. Power on your Satellite Router.
4. In the Windows Start menu of your Laptop, select **All Programs**→**Accessories**→**Communications**→**HyperTerminal** to open the Connection Description dialog box.



Figure 1. HyperTerminal Connection Description Dialog Box

5. In the Connection Description dialog box, type a Name for the connection, such as Satellite Router Console.
6. Optionally, you can select an Icon other than the default icon for your connection.

-
7. Click OK to display the Connect To dialog box.



Figure 2. HyperTerminal Connect To Dialog Box

8. Select COM1 from the Connect using drop-down menu.
9. Click OK in the Connect To dialog box to view the COM1 Properties dialog box.

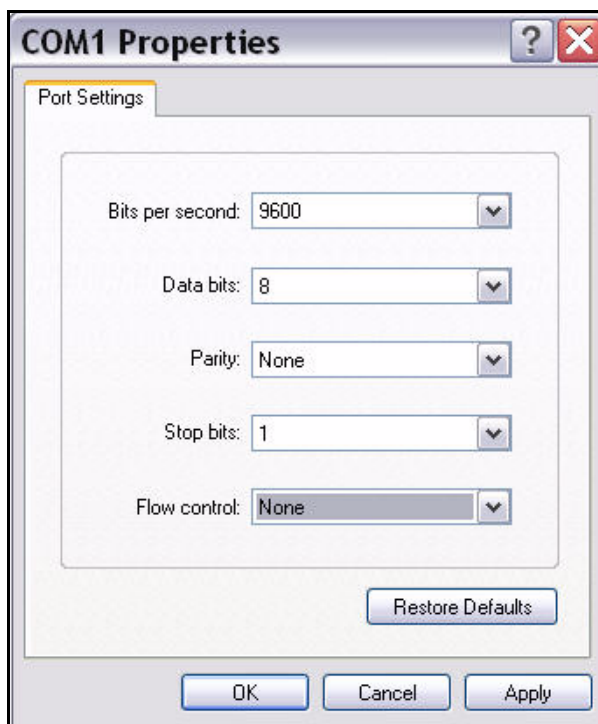

Figure 3. HyperTerminal COM1 Properties Dialog Box

10. Use the drop-down menus to select the COM1 Properties. Select the same settings as those shown in [Figure 3](#).

- Bits per second: 9600
- Data bits: 8
- Parity: None
- Stop bits: 1
- Flow control: None

11. Click OK to connect to the Satellite Router.

Note: *If this is a mobile remote and you lose contact with it, the console port settings will change during the boot process to 4800 bps. All other settings will remain the same. To re-establish communication with the console port, you must change your serial port settings to match the new settings.*

12. Press Enter a few times to generate a response from the Satellite Router. If you are successful, the console prompt will display. If you are unable to generate a response from the Satellite Router, re-examine your settings to be certain that they are correct.

13. At the iDirect login prompt, enter **root** ([Figure 4](#)).

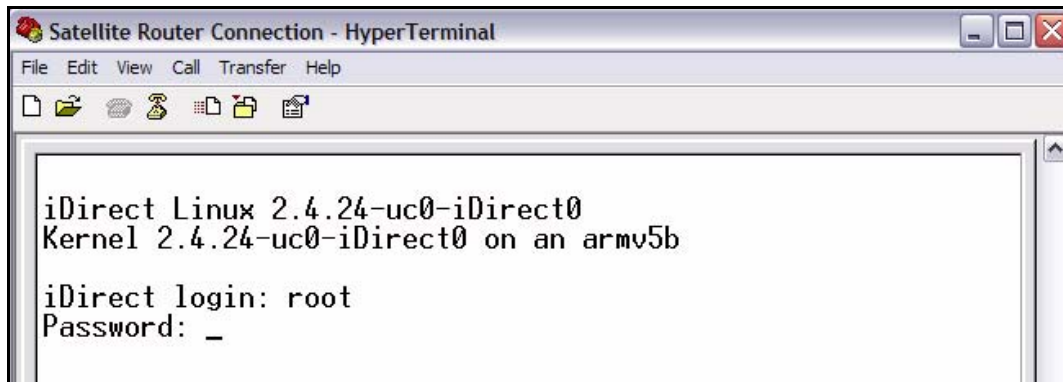

Figure 4. Logging On to root Account During a Console Session

14. At the Password prompt, enter the default password, **iDirect**.

You are now logged on to the Linux software running on your Satellite Router. Perform the steps in the next section to telnet to the iDirect Application.

3.2 Telnet to the iDirect Application

1. At the Linux prompt (`#`), enter `telnet 0` to telnet to the iDirect application (Figure 5).

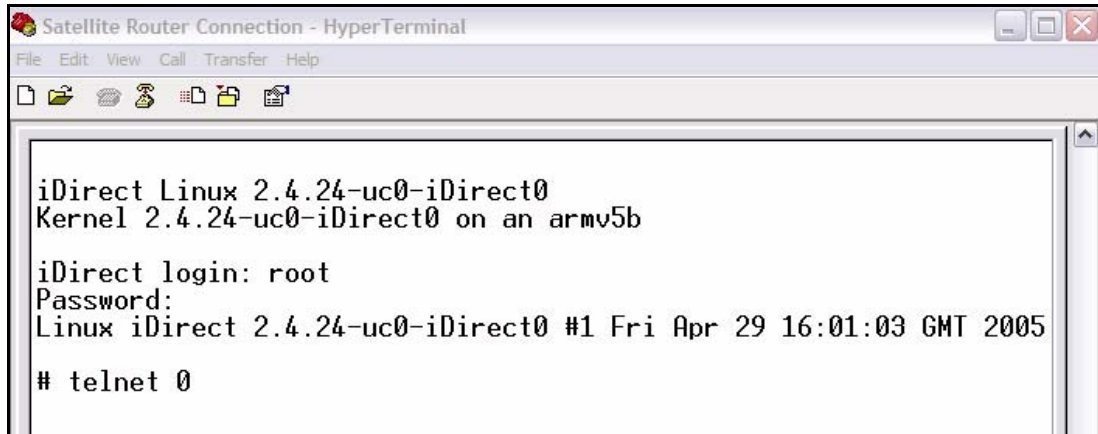

```
Satellite Router Connection - HyperTerminal
File Edit View Call Transfer Help
iDirect Linux 2.4.24-uc0-iDirect0
Kernel 2.4.24-uc0-iDirect0 on an armv5b
iDirect login: root
Password:
Linux iDirect 2.4.24-uc0-iDirect0 #1 Fri Apr 29 16:01:03 GMT 2005
# telnet 0
```

Figure 5. Telnetting to iDirect Application During a Console Session

2. At the Username prompt, enter the default user name, `admin` (Figure 6).

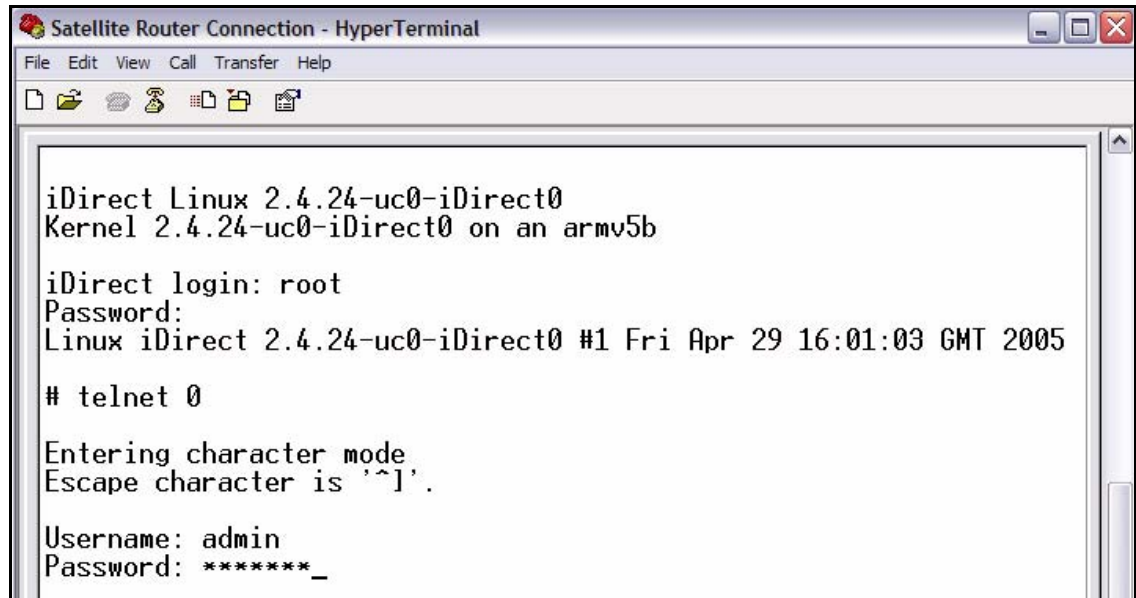

```
Satellite Router Connection - HyperTerminal
File Edit View Call Transfer Help
iDirect Linux 2.4.24-uc0-iDirect0
Kernel 2.4.24-uc0-iDirect0 on an armv5b
iDirect login: root
Password:
Linux iDirect 2.4.24-uc0-iDirect0 #1 Fri Apr 29 16:01:03 GMT 2005
# telnet 0
Entering character mode
Escape character is '^['.
Username: admin
Password: *****_
```

Figure 6. Logging On to Admin Account During a Console Session

3. At the Password prompt, enter the default password, `iDirect`. (In some cases, `P@55w0rd!` may be the default password.)

You are now logged on to the iDirect application. To determine the IP address and firmware version of the Satellite router, perform the steps in the next section.

3.3 Discovering the Satellite Router's IP Address and Application Version

1. At the Satellite Router prompt, enter the command `laninfo` (Figure 7).

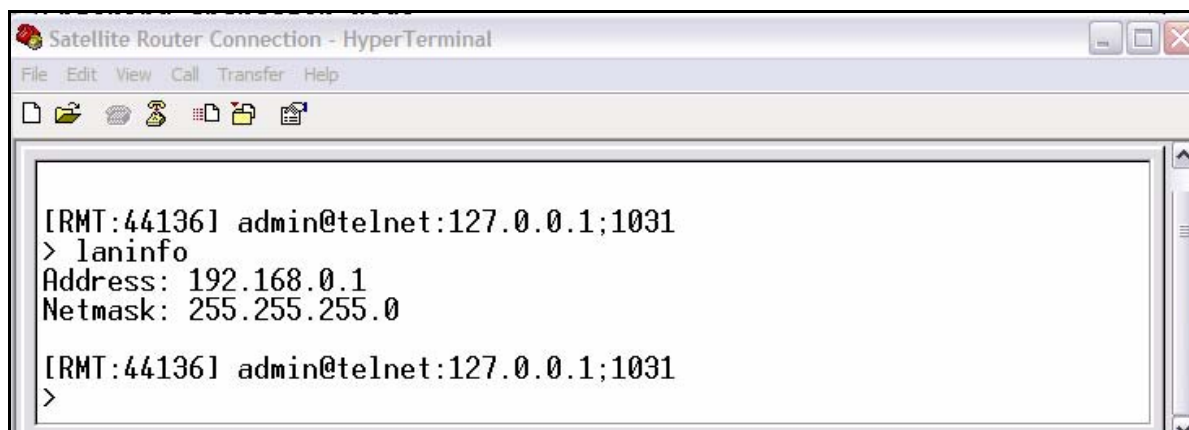

```
[RMT:44136] admin@telnet:127.0.0.1;1031
> laninfo
Address: 192.168.0.1
Netmask: 255.255.255.0

[RMT:44136] admin@telnet:127.0.0.1;1031
>
```

Figure 7. Entering the `laninfo` Command

When you enter the `laninfo` command, the IP Address and Netmask currently assigned to the Satellite Router are displayed. In the example in Figure 7, the IP address is 192.168.0.1 and the subnet mask is 255.255.255.0. You will need this information to configure your laptop to be in the same subnet as the Satellite Router.

Now that you have determined the IP address of the Satellite Router, determine the current version of the iDirect application to know whether or not you should select Secure Connection when first logging on to iSite. See page 14 for details.

2. At the Satellite Router prompt, enter the `version` command to determine the current version of the iDirect application running on the Satellite Router (Figure 8).

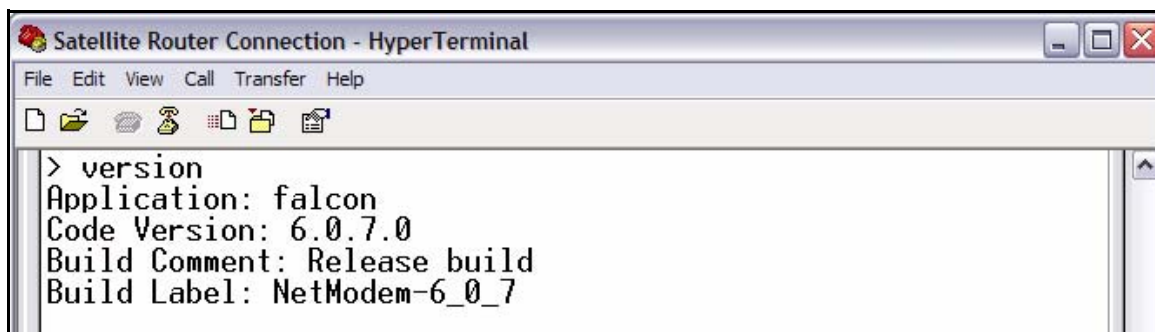

```
> version
Application: falcon
Code Version: 6.0.7.0
Build Comment: Release build
Build Label: NetModem-6_0_7
```

Figure 8. Entering the `version` Command

In Figure 8, the Satellite Router is running Code Version 6.0.7.0.

3.4 Modify Your Laptop's IP Address and Subnet Mask

To modify the IP address of your laptop, you must bring up the Windows Network Connections window and modify the TCP properties.

1. From your computer's Control Panel, double-click Network Connections.
2. Double-click the icon for your Local Area Connection to launch the Local Area Connection Status dialog box.

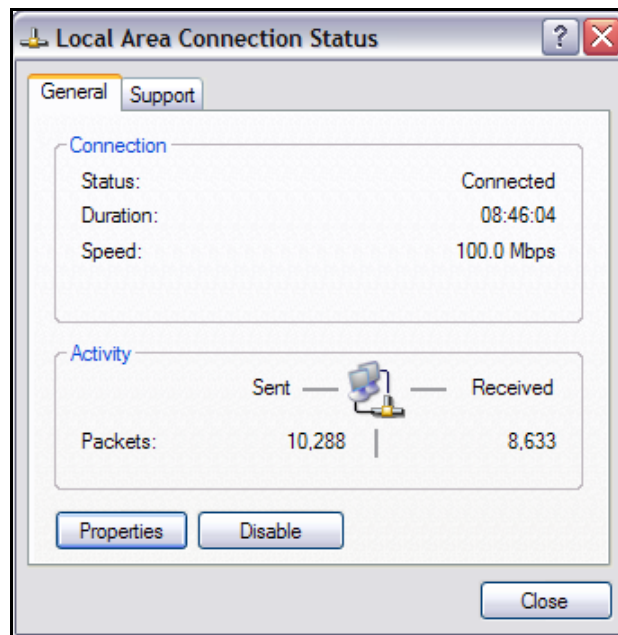

Figure 9. Local Area Connection Status Dialog Box

3. Click the Properties button to display the Local Area Connection Properties dialog box.

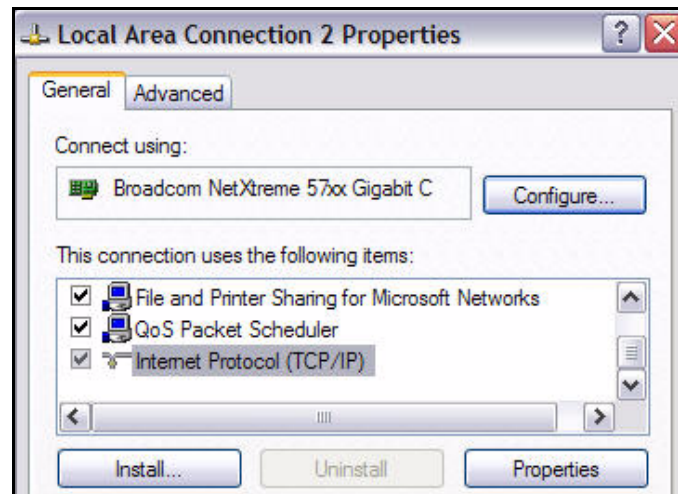

Figure 10. Local Area Connection Properties Dialog Box

-
4. In the Local Area Connection Properties dialog box, under This connection uses the following items: select Internet Protocol (TCP/IP) as shown in [Figure 10](#).
 5. Click the Properties button to display the Internet Protocol (TCP/IP) Properties dialog box.

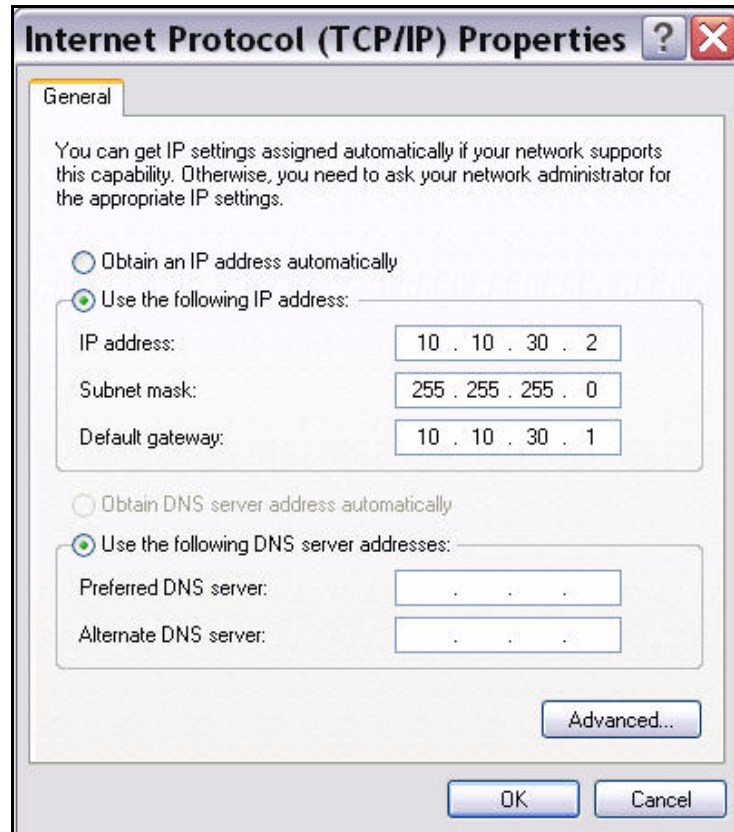

Figure 11. Internet Protocol (TCP/IP) Dialog Box

6. In the Internet Protocol (TCP/IP) Properties dialog box, select Use the following IP address. Type an IP address that is inside the range specified by the Satellite Router's IP address and subnet mask.
7. Type the same Subnet mask that you retrieved from the Satellite Router using the `Ianinfo` command. For the purposes of a local connection, you do not need to specify DNS server addresses.
8. Type the Satellite Router's IP address as the Default Gateway address.
9. Click OK to save your changes.

You are now ready to connect to the Satellite Router using iSite.

Note: *You can ping the IP address of the Satellite Router to verify that the connection has been successfully established.*



4 Downloading Packages to the Satellite Router

Perform the steps in this section to download the image packages containing software and firmware for the current release from your laptop to the Satellite Router.

1. Connect the LAN port of the laptop to the LAN B port of the Satellite Router using a crossover LAN cable. (Newer laptops adjust when you use a straight through cable, but older machines do not.)
2. Launch iSite. iSite automatically discovers the Satellite Router in the iSite Tree View, as shown in [Figure 12](#).

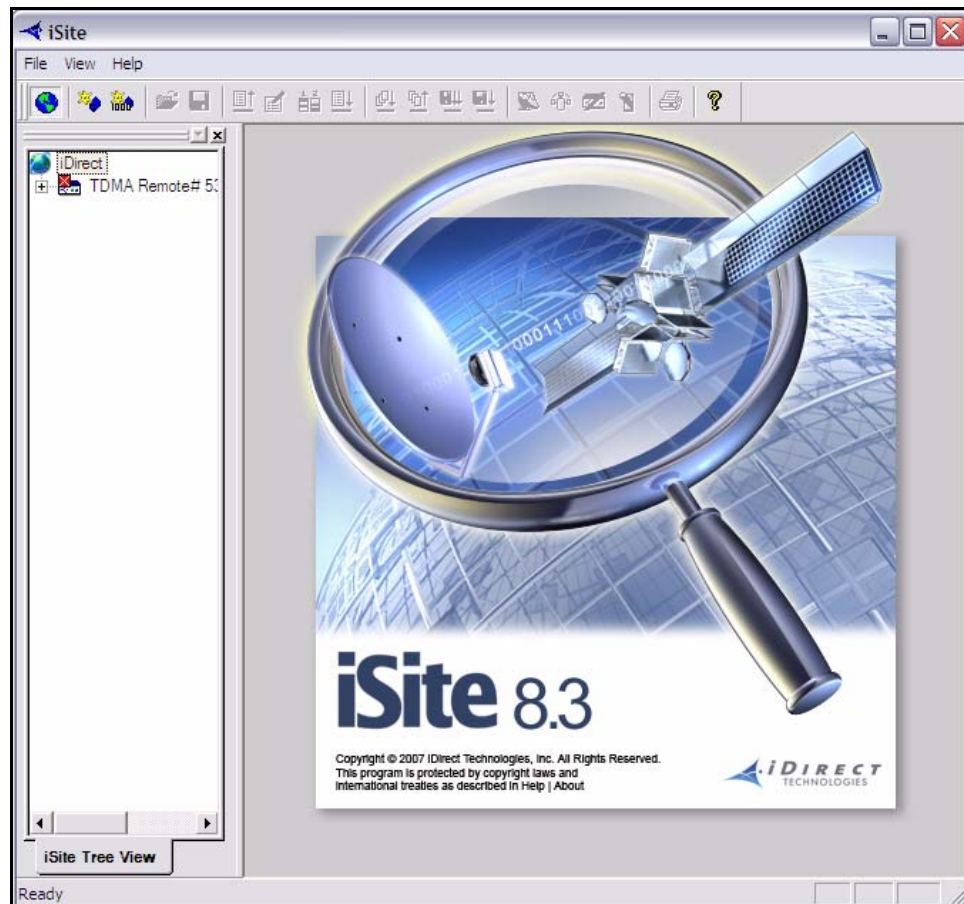
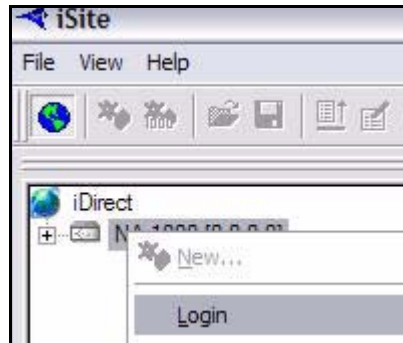

Figure 12. iSite Welcome Screen

Note: If iSite does not automatically discover the Satellite Router, right-click the iDirect globe in the iSite tree and select New from the menu to add an unknown element to the tree. Then right-click the new element and log on using the IP address of the router.

3. Right-click the Satellite Router in the iSite Tree View and select Login.



The Login dialog box opens, pre-configured with your Satellite Router's IP Address.

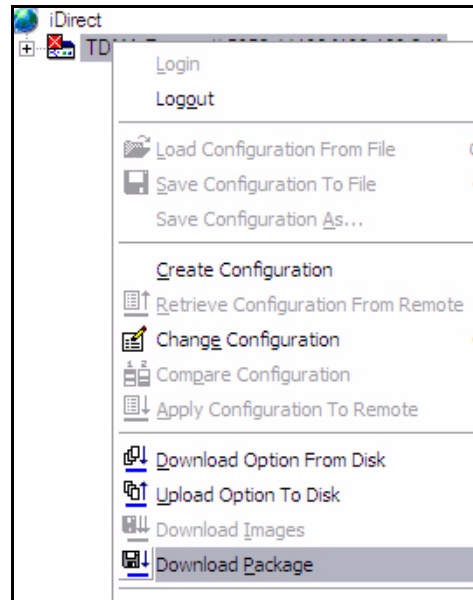

Figure 13. iSite Login Dialog Box

4. Type the default Password, "iDirect".
5. In the Login as section of the dialog box:
 - a. Select Admin.
 - b. Select or clear the Secure Connection check box, depending on the version of the iDirect application that you determined when you entered the `version` command on [page 9](#).

If a pre-7.1 version of the iDirect application is currently installed on the Satellite Router, clear the Secure Connection check box. If later images have already been installed, select Secure Connection.
6. Click OK to log on to the Satellite Router.

-
7. Right-click the Satellite Router in the iSite Tree View and select Download Package.



The Download Package dialog box opens.

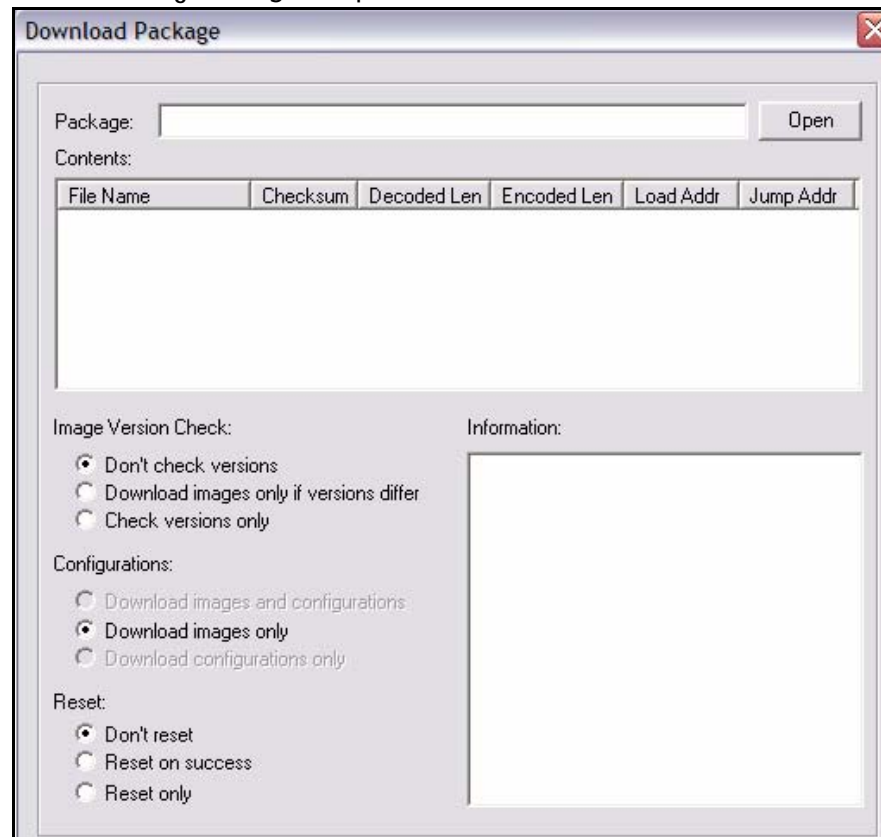

Figure 14. Download Package Dialog Box

8. In the Download Package dialog box, click the Open button to display the Open dialog box.

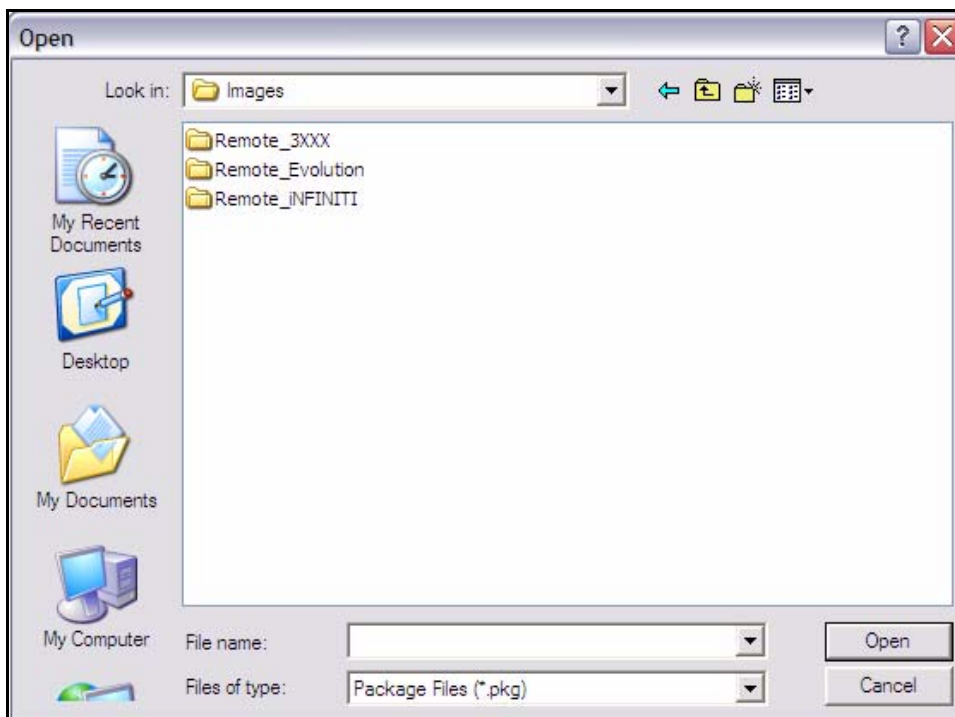

Figure 15. Open Dialog Box with Images Folder

9. Navigate to the remote packages on your laptop. They are located in the Images folder for your release, as illustrated in [Figure 15](#).
10. In the Open dialog box, double-click the folder for your Satellite Router model to open the folder. For each model type, [Table 1](#) identifies the folder containing the packages you must download and the required packages.

Table 1. Remote Image Packages

Satellite Modem	Location	Packages to Download
iNFINITI 3000 Series	NetModem-<version>/Images/Remote_3XXX	cumulative_update package remote_3XXX package
Evolution e8350	NetModem-<version>/Images/Remote_Evolution	evo_bsp package evo_l_rmt package
iNFINITI Series (except 3000 Series)	NetModem-<version>/Images/Remote_iNFINITI	cumulative_update package remote package

Note: As shown in [Table 1](#), the remote package for iNFINITI 3000 Series Satellite Routers is different from the remote package for other iNFINITI models.

You must download two packages to your Satellite Router: the Cumulative Update or BSP package, and the remote image package. Figure 16 shows the packages for each Satellite Router model supported in iDS Release 8.3.

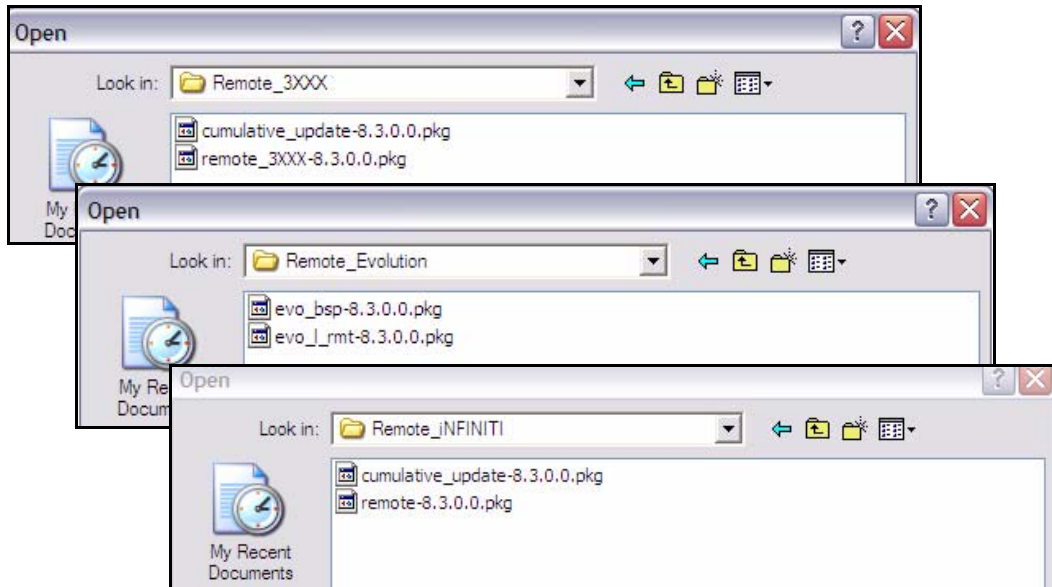

Figure 16. Remote Packages for Satellite Router Models

Note: You must download both packages to your Satellite Router, beginning with the cumulative update or BSP package.

Note: During this time, observe the output of both iSite and a console session to verify that the download is complete before going on to the next step. iSite may not be synchronized with the console.

11. Double-click the cumulative update package or board support package in the Open dialog box to return to the Download Package dialog box.

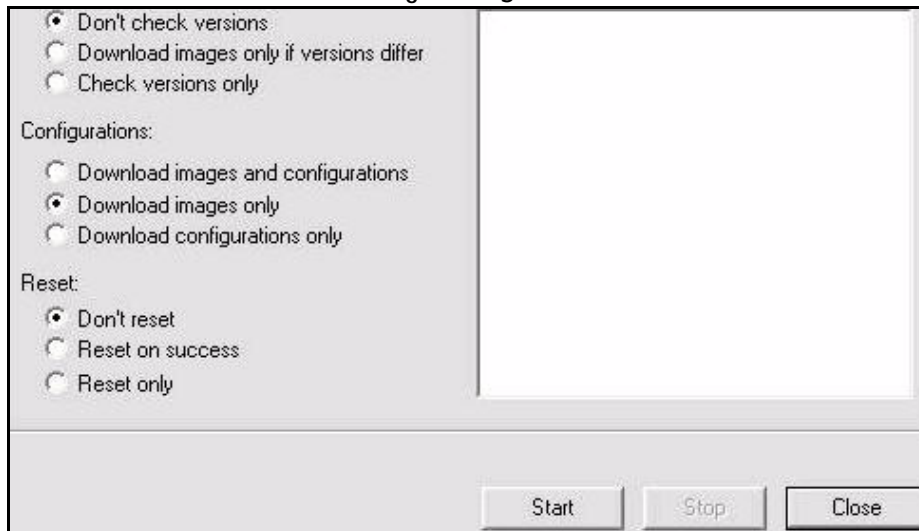

Figure 17. Download Package Dialog Box with Correct Selections

-
12. In the Download Package dialog box, select the options show in [Figure 17](#):
 - Don't check versions
 - Download images only
 - Don't reset
 13. Click the Start button.
 14. Wait while the download progresses. Observe the Information section of the Download Package dialog box until the word Done is displayed.

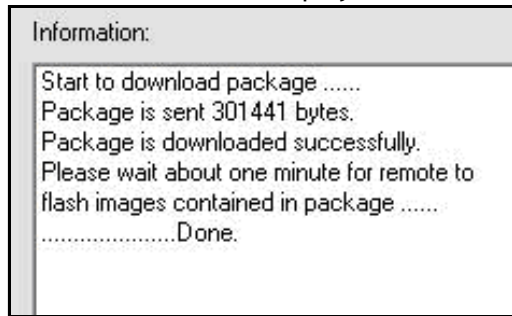

Figure 18. Download Package Dialog Box: Information Section

When the download of the cumulative update or board support package has finished, you must perform similar steps to download the remote image package to the Satellite Router.

1. Click the Open button in the Download Package dialog box again ([Figure 14](#) on [page 15](#)) and navigate back to the folder containing the remote packages for your Satellite Router.

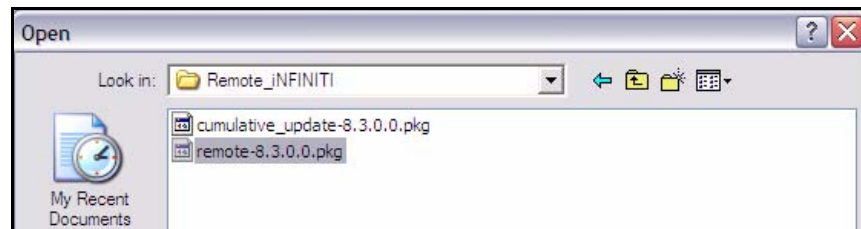

Figure 19. Remote Packages With Remote Image File Selected

2. Double-click the remote image package in the Open dialog box to return to the Download Package dialog box.

[Figure 19](#) shows the Open dialog box with the remote image file for the iNFINITI series Satellite Routers highlighted (except for the 3000 series). [Figure 16](#) shows the packages for all model types.

3. In the Download Package dialog box, select the following options, as shown in [Figure 17](#) on [page 17](#).
 - Don't check versions
 - Download images only
 - Don't reset
4. Click the Start button.

-
-
5. Wait while the download progresses. Observe the Information section of the Download Package dialog box until the word Done is displayed.

Once you have downloaded both packages to your Satellite Router, perform the steps in the next section to download the options file.



5 Downloading the Options File to the Satellite Router

Perform the steps in this section to download the remote options file to the Satellite Router.

1. In iSite, right-click the Satellite Router and select Download Option from Disk.

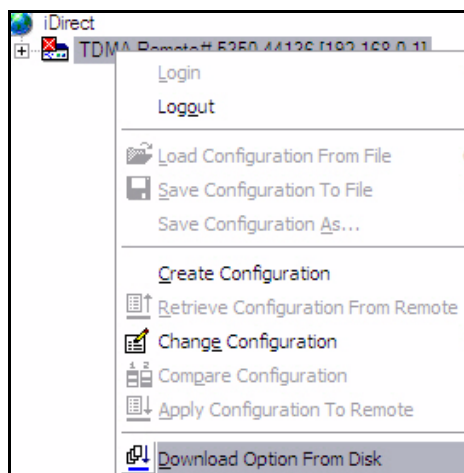

2. In the Open dialog box, navigate to the folder on your laptop containing the remote options file.

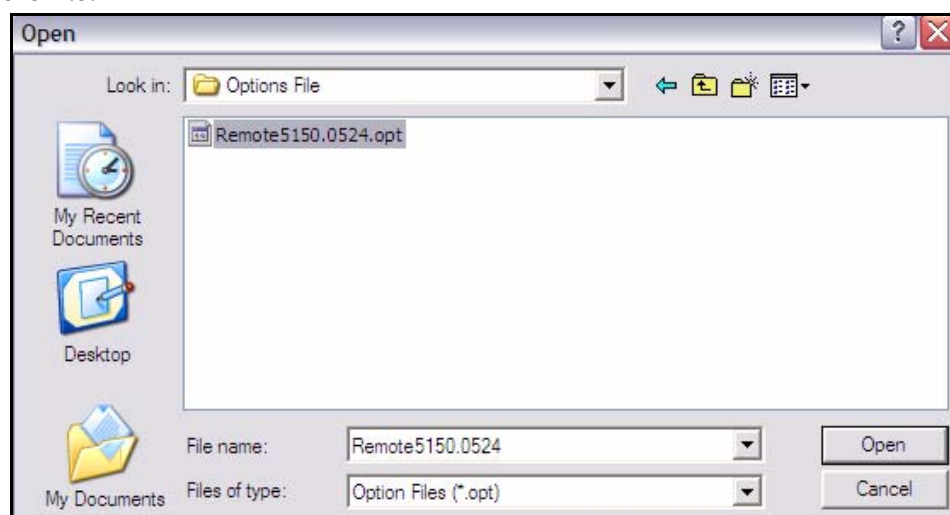

Figure 20. Open Dialog Box with Remote Options File Selected

-
3. Select the options file and click the Open button.
 4. When iSite requests confirmation of the download request, click the Yes button.

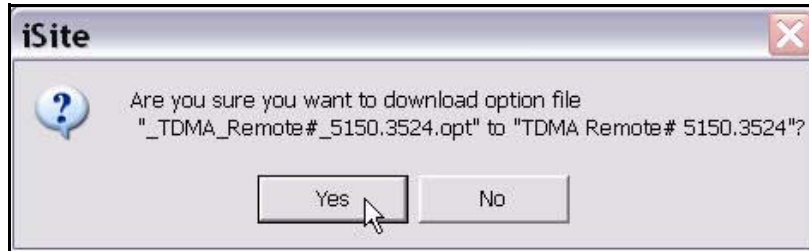

Figure 21. iSite Options File Download Confirmation Dialog Box

5. When iSite reports a successful download, click the Reset Now button to reset the Satellite Router.

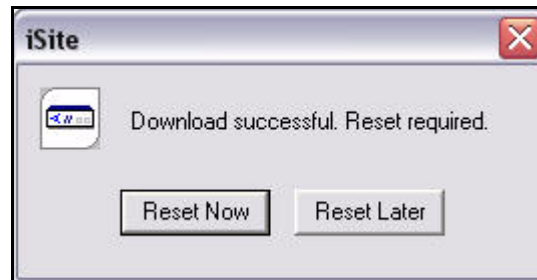

Figure 22. Resetting the Satellite Router After Download

Note: *Resetting logs you out of the Satellite Router. After the reset, the IP address of the Satellite Router changes to the value provided by your Service Provider in the downloaded options file.*

Note: *If your Service Provider changed your Satellite Router password from the default iDirect password, log on to the router using the new password.*

6 Setting Up your Antenna

Perform the steps in this section to set up your antenna.

6.1 Select a Site for the Antenna

1. Select a level surface that is approximately 10 feet by 10 feet.
2. Verify that nothing is blocking the line of site to the satellite in azimuth and elevation.
3. Verify that the IFL cable can reach the Satellite Router from the antenna location. (RG-6 IFL cable may be used up to a distance of 250 feet. If your run is longer, RG-11 cable must be used up to a distance of 500 feet.)
4. Ensure that the IFL cable does not cross roads or heavy foot-traffic areas.

6.2 Assemble the Antenna

Assemble the antenna using the supplied assembly instructions. After installation, ensure that the following are true:

1. The antenna base is on a stable surface that will not shift during windstorms.
2. Ballast is installed on the antenna base.
3. The mast pipe is plumb.

6.3 Align the Antenna toward the Spacecraft

You are now ready to perform the initial alignment of your antenna.

1. Set the antenna's polarization to the approximate value provided by iSite's Look Angle Calculator.
2. Set the elevation to the value provided by iSite's Look Angle Calculator.

Note: *Using the Look Angle Calculator is discussed in detail in [“Calculate Polarization, Azimuth, and Elevation” on page 26.](#)*

Note: To take into consideration the magnetic angle of declination in your location and to ensure that the compass reading is correct, you must:

1. Take a reading at the back of the antenna

2. Mark a reference point some distance ahead of the antenna, so that you have something to point to.

Keep in mind that large metal objects can cause inaccurate compass readings.

A 1.8 meter antenna has 22.6° offset and a 1.2 meter antenna has 17° offset. For example, an elevation angle of 50° is set as follows for a 1.8 meter antenna:

$$50^{\circ} - 22.6^{\circ} = 27.4^{\circ}$$

The backplane is perpendicular to the line of sight of the antenna plus 22.6°. If the backplane is 90°, the antenna elevation angle is 22.6°.

In the example above the antenna is elevated from 90° to 117.4° or, depending on the type of inclinometer being used, a reading of 62.6°, to reach an elevation angle to 50°.

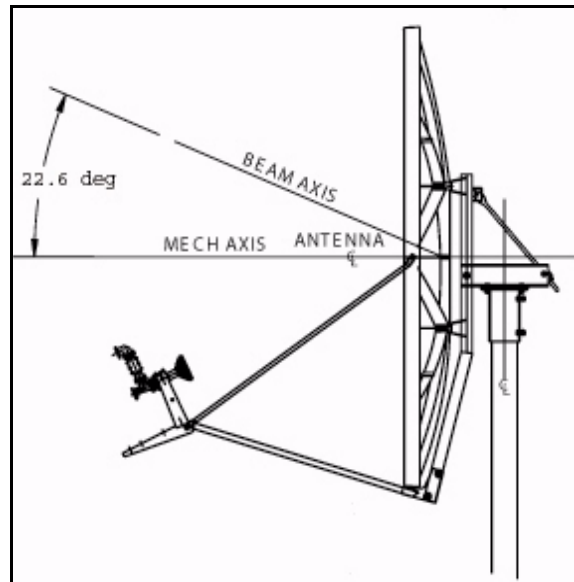

Figure 23. Antenna Elevation Offset

To prepare the antenna for pointing, move the antenna away from the desired azimuth, by swinging the antenna 20° in azimuth. This enables you to get a clear sky reading and compare signal strengths during the antenna pointing procedure.

7 Pointing the Antenna Using a Voltmeter

This section explains how to point the antenna using Pulse Width Modulation and iSite. An alternative pointing method is described in [Appendix B, “Pointing the Antenna Using Console Commands”](#) on page 57.

7.1 Prepare the Indoor Unit (IDU) and Outdoor Unit (ODU) for Pointing

1. If your Satellite Router is powered on, power it off at this time.
2. Ensure that the Receive IFL cable is connected from the LNB to the Satellite Router.
3. Ensure that the Transmit IFL cable is connected to the Satellite Router.
4. Disconnect the Transmit IFL cable from the BUC and connect it to a Digital Volt Meter.
5. Power on your Satellite Router.

7.2 Log in to Your Satellite Router

After powering on your Satellite Router, you should still have IP connectivity. Therefore, you can continue to access your Satellite Router using iSite.

1. Right-click your Satellite Router in the iSite Tree and select Login.

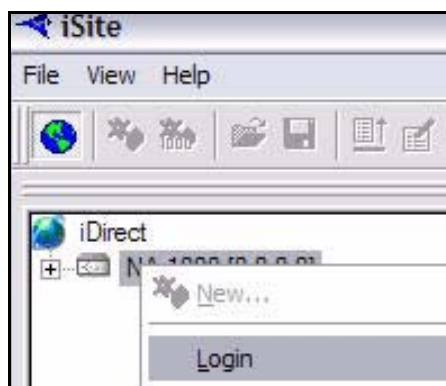

The Login dialog box opens, pre-configured with your Satellite Router's IP Address.



Figure 24. iSite Login Dialog Box

2. In the Login dialog box, type the IP Address of the Satellite Router.
3. Type the Password of the Admin account. (“iDirect” is the default password for the Admin account.)
4. In the Login As section of the dialog box:
 - a. Select Admin
 - b. Select Secure Connection.
5. Click OK.

Note: A new password may have been assigned at your Network Operator’s Help Desk. If you cannot log on using “iDirect”, obtain the correct password from the Network Help Desk.

Note: If you do not have Admin privileges, log in as User.

7.3 Calculate Polarization, Azimuth, and Elevation

Using iSite, calculate the polarization, azimuth, and elevation appropriate for your current location.

1. In the iSite Tree, right-click the Satellite Router and select Align Antenna→Antenna Pointing to display the Antenna Pointing dialog box (Figure 25).

Antenna Pointing

Look Angle Calculator | Antenna Pointing

Remote Location
 Latitude: Deg N. Longitude: Deg W.

Spacecraft Position
 Longitude: Deg W.

Elevation Information
 True: deg. Horizontal = 0 deg. Straight Up = +90 deg.
 Offset: deg.

Gross Antenna Pointing Information
 Elevation Actual: deg. Actual = True - Offset
 Azimuth True: deg. Geographical North = 0 deg.
 Polarization Offset: deg. Polarization Angle Sense

Notes:
 For observer behind antenna (facing the feed/satellite), positive is clockwise.
 For observer behind feed (facing the dish), positive is counter-clockwise.
 Polarization calculation is based on an operational horizontal downlink. If the operational downlink polarization is 'vertical', subtract 90 degrees from the calculated result to obtain the correct polarization value. A negative number is valid.

Close

Figure 25. iSite Antenna Pointing Dialog Box

2. On the Look Angle Calculator tab of the Antenna Pointing dialog box, the Longitude should already be configured for you in Spacecraft Position. If not, enter the appropriate Longitude for the satellite that you are using.

If you are commissioning a mobile remote, the white fields will be blank. You must supply the following information.

3. In Remote Location, enter the Latitude and Longitude of your current geographic location. For mobile remotes, this can be determined by your GPS unit.
4. In Spacecraft Position, enter the Longitude for the satellite that you are using.
5. In Elevation Information, type the Offset for your antenna.

The offset for a 1.8 meter antenna is 22.6°.

The offset for a 1.2 meter antenna is 17°.

When you have configured all of the information, iSite automatically calculates your polarization offset, azimuth, and elevation values.

Note: *Write these values down, or leave this screen open on your laptop. You will need these values later to perform the initial pointing of your antenna.*

7.4 Perform Pulse Width Modulation (PWM) Antenna Pointing

Next, you must fine-tune the antenna pointing by locking onto the downstream carrier for your network and sweeping the antenna in azimuth until you obtain a reading of 12 to 24 volts DC. Readings in this range indicate that you have successfully locked onto the correct satellite.

Table 2. Signal Strength Ranges (PWM)

<i>Signal Strength Ranges</i>	
Volts DC	Antenna Status
0 - 2	Not in pointing mode, hardware problem, or off satellite
2 - 10	Detecting RF energy, but not locked on the downstream carrier
12 - 24	Locked on the downstream carrier

Note: *You can only obtain a reading of 12 volts or greater when you are locked onto the correct spacecraft or network.*

If you are not already connected to the Satellite Router, power it on, launch iSite, and connect to the Satellite Router by following the instructions beginning on [page 13](#) of this manual.

1. In the iSite Tree View, right-click the Satellite Router and select **Align Antenna**→**Antenna Pointing** to display the Antenna Pointing dialog box ([Figure 25](#) on [page 27](#)).

2. Click the Antenna Pointing tab.

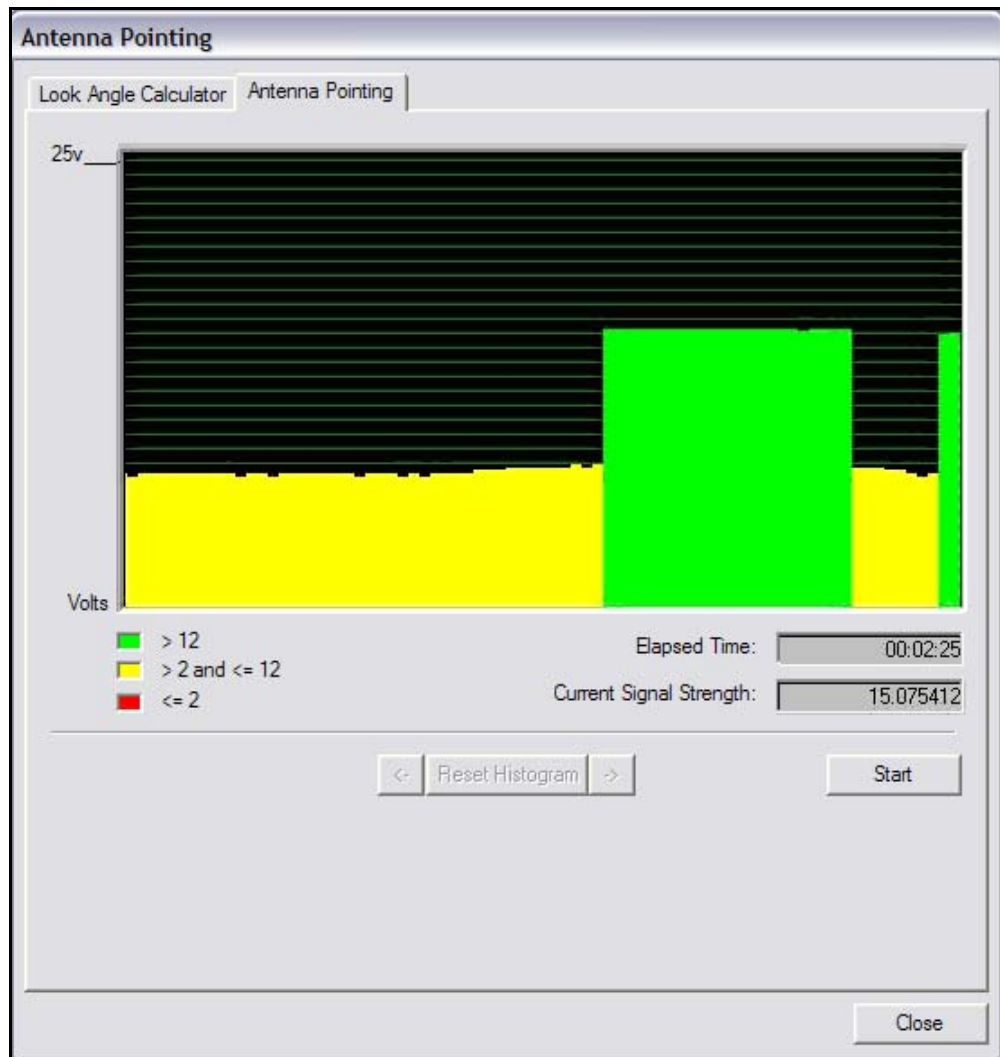

Figure 26. Comparing Signal Strength

3. Slowly sweep the reflector in azimuth until a signal of the appropriate strength is found. The signal reading on the pointing graph turns red, then yellow, and finally, completely green, as you sweep the reflector to lock on to the downstream carrier.

When you have achieved strong signal strength on the correct satellite, you should see:

- A green reading on the Antenna Pointing graph
- A reading within the desired range for the Current Signal Strength
- A signal within the correct range on your digital voltmeter (≥ 12 volts)

Figure 27 shows an example of the iSite Antenna Pointing graph when the antenna is locked onto the correct downstream carrier.

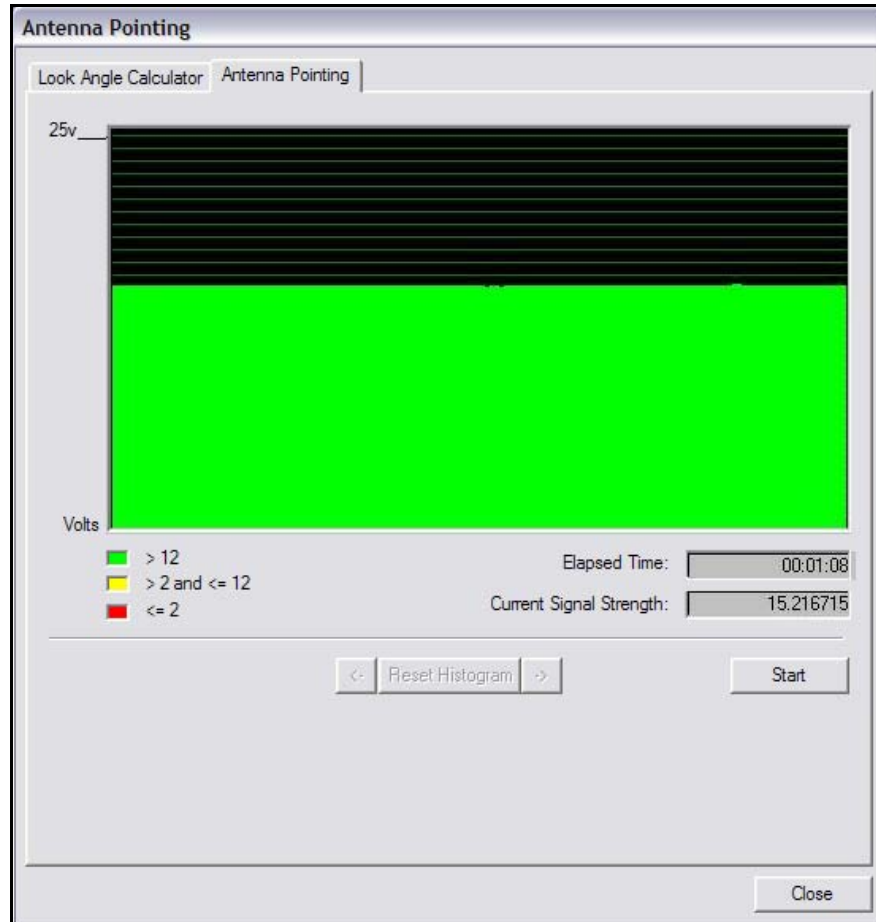

Figure 27. Locking on to a Carrier Stream

Note: *You cannot obtain a reading in the correct range from the wrong spacecraft or network.*

4. If the desired signal is not found, increase or decrease the elevation setting by 2° increments and repeat the azimuth sweep until the correct signal is found. (See [Step 5](#) on [page 27](#).)
5. When you have locked onto the carrier:
 - a. Tighten the four bolts on the Yoke Cap that secure the Yoke Cap to the Mast Pipe.
 - b. Ensure that the Top Plate locking bolts are snug to allow azimuth movement.
 - c. Adjust the elevation until maximum DC voltage is obtained.

-
-
6. Make the remaining azimuth adjustments with the azimuth adjustment screws:
 - a. Fine tune azimuth until maximum DC voltage is obtained.
 - b. Make sure azimuth and elevation are locked down.
 - c. Adjust the polarization until maximum DC voltage is obtained.
 7. Write down the final antenna pointing voltage reading and report the reading to the operator at the Network Help Desk.
 8. In the Antenna Pointing dialog box, click Stop to exit the modem's antenna pointing mode.
 9. Power off the Satellite Router.

Note: *You must power off the Satellite Router before continuing to the next section, ["Tuning Antenna Pointing and Cross Polarization" on page 33.](#)*



8 Tuning Antenna Pointing and Cross Polarization

Perform these steps to fine-tune the antenna pointing and cross polarization.

8.1 Set up the Satellite Router for Cross Polarization

1. Power off the Satellite Router to set it up for cross polarization.
2. Disconnect the receive IFL cable from the Satellite Router.
3. Disconnect the transmit IFL cable from the Digital Volt Meter and connect it to the BUC.

8.2 Set up iSite for Cross Polarization

The remote portion of the cross polarization test is conducted from the iSite GUI.

1. Power on the Satellite Router.
2. Launch iSite and connect to the Satellite Router using its IP address.
3. Log on as Admin with a valid password.
4. In the iSite menu bar, select **Align Antenna**→**Cross Polarization** from the **Configure** menu to open the **Cross Polarization** dialog box.

The image shows a screenshot of the 'Cross Polarization' dialog box. The dialog box has a title bar with the text 'Cross Polarization'. Below the title bar, there are two main sections. The first section is titled 'Specify Transmit Frequency' and contains three input fields: 'RF Uplink Frequency: 0 MHz', 'BUC LO Frequency: 0 MHz', and 'L-Band TX Frequency: (Absolute Value) 0 MHz'. The second section is titled 'Adjust Transmit Power' and contains a 'Transmit Power: -25.0 dBm' field with up and down arrows. There are three buttons: 'Start', 'Stop', and 'Close'.

Figure 28. Cross Polarization Dialog Box

8.3 Preparing for the Cross Polarization Test

1. While still logged on to iSite, call the Network Help Desk. The Network Operator will establish a conference call between you, the Help Desk, and the satellite provider.
2. Provide the final antenna pointing voltage reading to the operator at the Network Help Desk. He will record the value for their records.
3. Obtain the test frequency from the satellite provider
4. In RF Uplink Frequency of the **Cross Polarization** dialog box (Figure 28), type the test frequency.

The BUC LO frequency is read from the options file on your Satellite Router. Using these values, iSite automatically calculates the L-band TX frequency.

5. Verify the L-band TX frequency with the Network Help Desk operator.

The BUC LO frequency typically shows a value of 13050 MHz for Ku band and 4900 for C band. These values are read from the options file on your Satellite Router. Using the RF Uplink and BUC LO frequencies, iSite automatically generates an L-band frequency for the Satellite Router.

8.4 Running the Cross Polarization Test

1. When instructed by the satellite provider, click the Start button on the Cross Polarization dialog box (Figure 28). This programs the Satellite Router with the calculated L-band frequency.

WARNING! Do not click the Start button until instructed to do so by the satellite provider. When you do click Start, your Satellite Router starts transmitting a Continuous Wave Carrier, or “CW.”

WARNING! You may receive an error message after clicking the Start button. If this happens, click the Stop button and try again.

2. If the Satellite Provider asks you to adjust the Satellite Router’s transmit power, select the appropriate power value in the Transmit Power box.

The satellite provider will ask you to adjust the azimuth, polarization, and/or elevation. The polarization is typically adjusted first. If the correct isolation cannot be achieved, then the operator may ask you to adjust the azimuth and/or elevation.

8.4.1 Adjusting Azimuth

1. Adjust the azimuth and the elevation by making $\frac{1}{4}$ turns of the adjustment nut. Then wait for the satellite provider to measure the cross polarization reading. The provider will instruct you to continue adjusting in the same direction or to reverse the direction.
2. Adjust the azimuth by loosening all four bolts on top of the canister as little and as evenly as possible.

WARNING! Loosening the four bolts too much, or adjusting some of them more than others, will throw off the elevation more than necessary.

-
-
3. After the azimuth has been adjusted, ensure that the four bolts and the fine adjustment rod are completely tightened, so that the elevation is not affected later.

8.4.2 Adjusting Elevation

The elevation adjustment is performed in the same manner as the azimuth adjustment.

1. Using the elevation rod/nut, adjust the elevation.
2. Once the elevation is adjusted, make certain that the elevation rod and nuts are completely tightened.

8.4.3 Adjusting the Polarization

To adjust the polarization:

1. Loosen the two screws at the feed.
2. Loosen the hose clamp on the back end of the BUC just enough that the entire assembly (feed, BUC, and LNB) rotates freely.
3. At the instruction of the satellite provider, move the feed in one direction in approximately $1/2^\circ$ increments, or as little as possible.
4. Wait for the satellite provider to take a measurement. The satellite provider may tell you to continue moving the feed in the same direction, or to reverse the direction. Continue until the satellite provider tells you that the polarization is peaked.
5. Tighten the two screws and the hose clamp to secure the outdoor unit.

At this point, the canister bolts on the pole should be completely tightened.

8.4.4 After the Cross Polarization Test

1. Wait for the Satellite Provider to verify that the cross polarization is still correct after everything is tightened.
2. Confirm that the Network Operator at the help desk has recorded the cross polarization results.
3. Proceed to the 1 dB Compression Point test.



9 Establishing the 1 dB Compression Point

Perform the 1 dB Compression Point test with the same CW setup used during the cross polarization test. This test determines the point at which the Satellite Router's transmit power saturates the BUC.

CAUTION: *To avoid overdriving the satellite, do not conduct this test if the power of the BUC exceeds five watts.*

1. With the iSite Cross Polarization dialog box still opened, and with the Network Operator watching the CW, increase the transmit power of the carrier in the Adjust Transmit Power drop-down box by 1 dBm increments.

CAUTION: *The operator should see the CW increase in power by approximately 1 dB. If the power does not increase, then the BUC may already be saturated. Although this scenario is unusual, it can occur.*

2. If power does not increase, decrease the power by 1 dBm until the operator sees the CW decrease by 1 dB.

Note: *The last point at which the CW changes by 1 dB is the 1 dB compression point.*

3. Record the TX power value. This will be entered into iBuilder as the maximum power for this remote used by the NMS.
4. Click the Stop on the button Cross Polarization dialog box to turn off the CW carrier. Then exit iSite.

The 1 dB compression point has now been established.

This completes the Satellite Provider's portion of the call. Disconnect the Satellite Provider from the call.

Do not power off the Satellite Router yet.



10 Recording Geo Location (Secure Mobile Remotes Only)

Follow the procedure in this section to set the geographical location of the Satellite Router for secure mobile remotes.

Note: *This section describes a specific operational scenario for configuring Satellite Routers as both Mobile and Secure. If your remotes do not fall into this category, skip this section.*

If for security reasons the Satellite Router's geographic location coordinates have not been recorded by the Network Help Desk, you must enter these coordinates into the Satellite Router manually before the modem can acquire into the network.

CAUTION: *It is critical that the geographic coordinates accurately reflect your current geographic location. If the values are incorrect, your Satellite Router will not be acquired into the network.*

10.1 Set the Satellite Router's Geo Location

Enter the latitude and longitude coordinates from the Satellite Router console using the `latlong` command.

1. Open a terminal session to the Satellite Router. (You can use HyperTerminal or TeraTerminal to create a serial connection to the console port. You can also use TeraTerminal or PuTTY to telnet to the Satellite Router over the LAN.)
2. Log in as root and telenet 0 to the Admin account. See [“Access Your Satellite Router Using HyperTerminal” on page 5](#) for details, including default passwords.
3. At the prompt, enter the following command:

```
latlong <your lat> [N|S] <your long> [E|W]
```

Format of the latlong Command

The format of the `latlong` command is: `latlong <lat> [N/S] <long> [E/W]`
When entering this command, replace the `<lat>` string with your current latitude in decimal notation, followed by N for north or S for south. Replace the `<long>` string with your current longitude in decimal notation, followed by E for east or W for west.

10.2 Verify the Satellite Router's Geo Location

Verify that you have entered the correct geographic location coordinates.

1. Enter `extras show` at the console prompt to display the current settings for latitude and longitude.
2. Reset the Satellite Router.

11 Bringing the Satellite Router into the Network

After you have entered the correct geographic coordinates for your current location and reset the Satellite Router, the Satellite Router should perform its power-up self-test and acquire into the network. Observe the LEDs on the front of the Satellite Router while the network powers on and goes through the acquisition process. You will see various combinations of front-panel lights indicating the current status of the Satellite Router.

The first time that the Satellite Router is acquired into the network, complete the post-acquisition activities described below. If your Satellite Router does not acquire into the network, contact the Network Help Desk for assistance. [Figure 29](#) shows the front panel of an iDirect iNFINITI Satellite Router. [Table 3](#) on page 42 and [Table 4](#) on page 43 specify the status of the iNFINITI and Evolution e8350 Satellite Routers, respectively, as indicated by the front panel LEDs.



Figure 29. iDirect 3000 series Satellite Router Front Panel

11.1 iNFINITI Front Panel LEDs

Various combinations of the LEDs on the front panel of the iNFINITI Satellite Router indicate the different states of your iDirect Satellite Router.

Table 3. iDirect iNFINITI LED Status

LED Label	LED Color	Indicated Unit Status
PWR	OFF	The Satellite Router is powered Off or there is a power supply problem.
	GREEN	The Satellite Router is powered On.
NET	GREEN	The Satellite Router has been acquired into the network.
	FLASHING GREEN	The Satellite Router is attempting acquisition into the network.
	SOLID YELLOW	The downstream SCPC is locked.
	FLASHING YELLOW	The downstream SCPC is not locked.
STATUS	GREEN	The IDU is functioning properly in TRANSEC mode.
	OFF	The IDU is functioning properly in non-TRANSEC mode.
	FLASHING GREEN	The unit is booting. The DRAM test is in progress.
	RED	Indicates a serious fault or failure in the software, hardware or configuration. May indicate that the DRAM test failed.
TX	GREEN	The IDU's transmitter is active.
RX	GREEN	The IDU is successfully locked to the downstream.
	YELLOW	The IDU is not locked to the downstream carrier.

11.2 Evolution e8350 Front Panel LEDs

Various combinations of the LEDs on the front panel of the Evolution e8350 Satellite Router indicate the different states of your iDirect Satellite Router.

Table 4. iDirect Evolution e8350 LED Status

LED Label	LED Color	Indicated Unit Status
PWR	OFF	The Satellite Router is powered Off or there is a power supply problem.
	GREEN	The Satellite Router is powered On.
NET	GREEN	The Satellite Router has been acquired into the network.
	FLASHING GREEN	The Satellite Router is attempting acquisition into the network.
	SOLIDYELLOW	The downstream SCPC is locked.
	FLASHING YELLOW	The downstream SCPC is not locked.
STATUS	GREEN	The IDU is functioning properly.
	FLASHING GREEN	The unit is booting. The DRAM test is in progress.
	RED	Indicates a serious fault or failure in the software, hardware or configuration. May indicate that the DRAM test failed.
TX	GREEN	The IDU's transmitter is active.
RX	GREEN	The IDU is locked to the downstream and receiving data.
	YELLOW	The IDU is not locked to the downstream carrier.



12 Post Acquisition Activities

To guarantee trouble-free operation of your Satellite Router, certain activities should be completed after the Satellite Router comes into the network for the first time. Some of these activities are performed by the Network Help Desk. Other activities are performed by you.

12.1 Network Help Desk Duties

After commissioning the Satellite Router for the first time and after it has acquired into the network, the Network Help Desk will take control of the Satellite Router to perform the following tasks.

WARNING! Do not power down the Satellite Router during this time.

1. The Network Help Desk will follow the procedure in [“Adjusting Power and Setting UCP Parameters” on page 47](#) to set the initial transmit power, maximum transmit power, and UCP settings for the remote. For star remotes, initial transmit power is typically set to 2 to 3 dB above nominal transmit power in clear sky conditions. For mesh remotes, initial power is determined by UCP adjustments made by the hub. Maximum transmit power is set for the 1 dB compression point.

WARNING! Setting the initial power too high above the normal operating levels can cause problems with the remote acquiring into the network or cause problems on the network.

2. The Network Help Desk will download the updated configuration to the Satellite Router and issue a reset.
3. The Network Help Desk will record levels of the Satellite Router as a baseline for troubleshooting.
4. The Network Help Desk will ensure that the software and firmware on the Satellite Router are at the correct revision level. If necessary they will upgrade the software on the Satellite Router and issue a reset.

The Network Help Desk will let you know when they are finished.

12.2 Remote Installer Duties

After the Network Help Desk has made any necessary adjustments to the Satellite Router's configuration, you should record some baseline readings for local reference, in case the antenna is moved, or some other service issue arises. Follow this procedure to record the baseline readings.

1. Open a terminal session to the Satellite Router. (You can use HyperTerminal or TeraTerminal to create a serial connection to the console port. You can also use TeraTerminal or PuTTY to telnet to the Satellite Router over the LAN.)
2. Log in as root and telenet 0 to the Admin account. See [“Access Your Satellite Router Using HyperTerminal” on page 5](#) for details, including default passwords.
3. At the prompt, enter the `rmstat` command to view the remote status message.

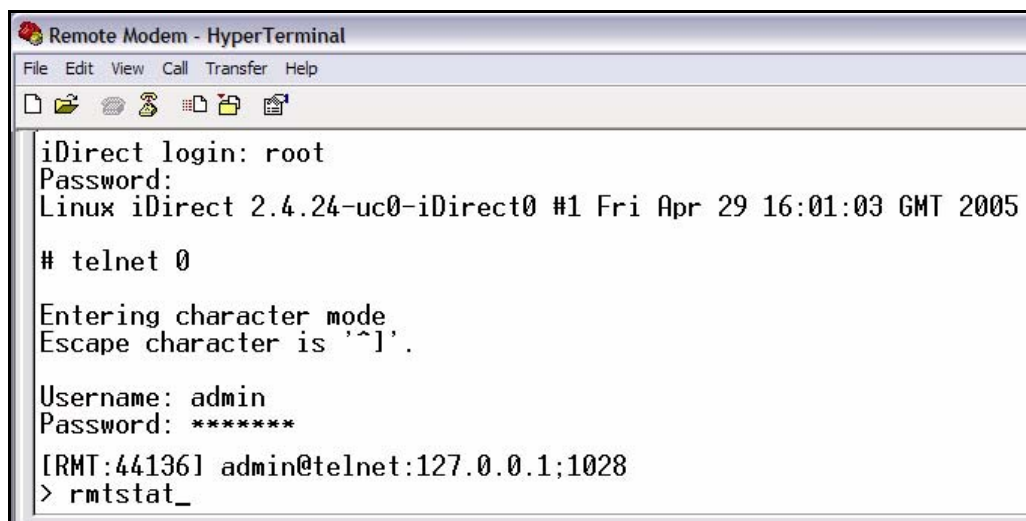

```
Remote Modem - HyperTerminal
File Edit View Call Transfer Help
iDirect login: root
Password:
Linux iDirect 2.4.24-uc0-iDirect0 #1 Fri Apr 29 16:01:03 GMT 2005
# telnet 0
Entering character mode.
Escape character is '^]'.
Username: admin
Password: *****
[RMT:44136] admin@telnet:127.0.0.1;1028
> rmstat_
```

Figure 30. Entering the `rmstat` Command

4. Record the following data from the remote status message:
 - a. Receive SNR of the Satellite Router (> 10.0 dB, Clear Sky Conditions)
 - b. Transmit power of the Satellite Router
 - c. Receive composite power into the Satellite Router. (-60 to -5 dBm)
 - d. Temperature reading in Celsius

Example: Remote Status Message

```
RemoteStatus: t:000017435715 SNR=15.60 RxPower=-33.79 dBmTxPower=-15.00 dBm
DigitalRxPower=21.07 Temp=49.1 TDM_Lost=0Flldac = 1812 LAN Port: 10 Mbps Half Duplex
(AutoNegotiation: None)
```

These readings should be checked periodically to ensure that the service is not degrading. These readings will be monitored from the Network Help Desk. Heavy weather or sandstorms can cause these levels to change. During heavy weather or sandstorms the levels should be monitored because it is important that they return to the original readings once the weather or sandstorm has cleared.

13 Adjusting Power and Setting UCP Parameters

Once you have completed the 1 dB compression test, the hub operator must set the following parameters for the remote in iBuilder:

- Maximum transmit power
- Initial transmit power
- Clear sky C/N for the SCPC downstream carrier. (Mesh remotes only.)
- Loopback Clear Sky C/N for the TDMA mesh carrier. (Mesh remotes only.)
- Clear Sky C/N for the mesh inroute group. (During commissioning of the *first* remote in a mesh inroute group.)

Contact the Network Help Desk and ask the hub operator to follow the instructions in this section to set these parameters. Provide the hub operator with the results of the 1 dB compression test. The hub operator will enter this value as the maximum transmit power for the remote.

13.1 Set the Maximum Tx Power for a Remote

Follow this procedure to set the maximum transmit power for the remote:

1. In iBuilder, right-click the remote in the network tree and select Modify→Item from the menu.
2. Select the Information tab of the Remote dialog box ([Figure 31](#)).

The screenshot shows the 'Remote' configuration tab in iBuilder. The 'Transmit Properties' section is expanded, showing the '1 dB compression point' field set to '0'. The 'Max Power' field is also set to '0'. Other fields like 'Initial Power' are set to '-18' dBm. The 'Carrier Name' is 'Tim G 8.3 U/S #1' and the 'L-Band Frequency' is '1115.000 MHz'.

Figure 31. iBuilder Remote Information Tab: Setting Max Power

3. In the Transmit Properties section of the dialog box, enter the 1 dB compression point as the value for Max Power.
4. Click **OK** to save the changes.
5. Right-click the remote in the network tree and apply the configuration.

13.2 Set the Initial Tx Power for a Remote

Perform these steps to determine and set the initial transmit power of the remote.

Note: *You must determine the initial transmit power setting under clear sky conditions.*

WARNING! *Following this procedure to determine the initial transmit power for a mesh remote while the remote is in a rain fade can result in a power setting that is too high. This can overdrive the power on the satellite.*

1. If you are commissioning a remote in a TRANSEC network, Disable Authentication for the remote on the iBuilder Remote Information tab and apply the hub-side configuration. (For more details, see the *iBuilder User Guide*, Appendix B, “Using the iDirect CA Foundry.”)
2. In iMonitor, right-click the remote in the network tree and select Probe from the menu to display the Probe dialog box for your network.

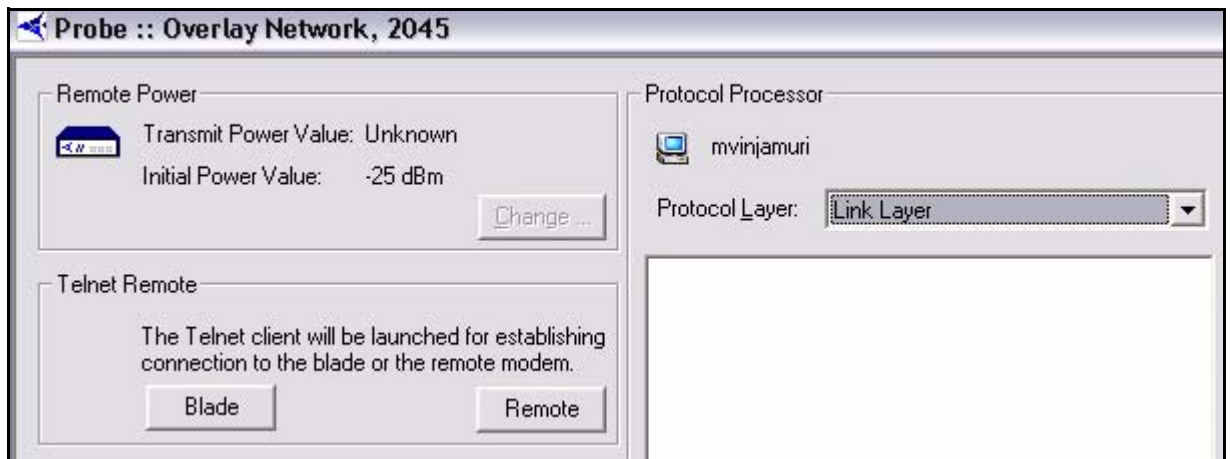

Figure 32. iMonitor Probe

3. In the Remote Power area of the screen, click the Change button to display the Change Remote Tx Power.

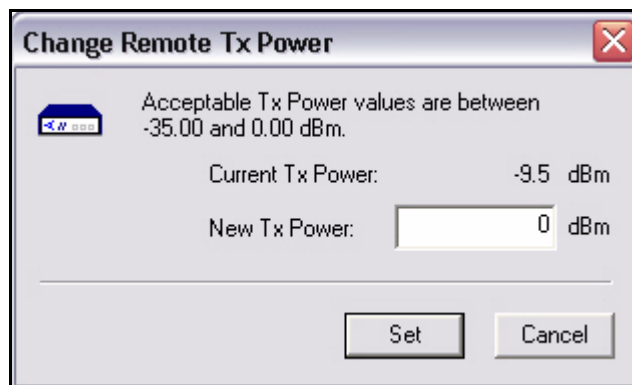

Figure 33. iMonitor Change Remote Tx Power Dialog Box

4. In the Change Remote Tx Power dialog box:
 - a. Type -25 in New Tx Power
 - b. Click Set.

Note: You can also base this initial setting on another remote in the network with similar antenna, BUC and geographic location.

- c. Increase the transmit power by increments of 3 dB until the remote acquires into the network.

Note: If you are commissioning the first remote on a mesh inroute, you must determine and set TDMA Clear Sky C/N for the mesh inroute at this time. Do not continue with this procedure until you have set that parameter. For details, see Chapter 14, “Commissioning a Line Card, Private Hub or Mini Hub” in the Network Management System iBuilder User Guide.

5. In iMonitor, right-click the remote in the network tree and select Remote Status/UCP from the menu to display the RemStats (Remote Status) dialog box for your network.

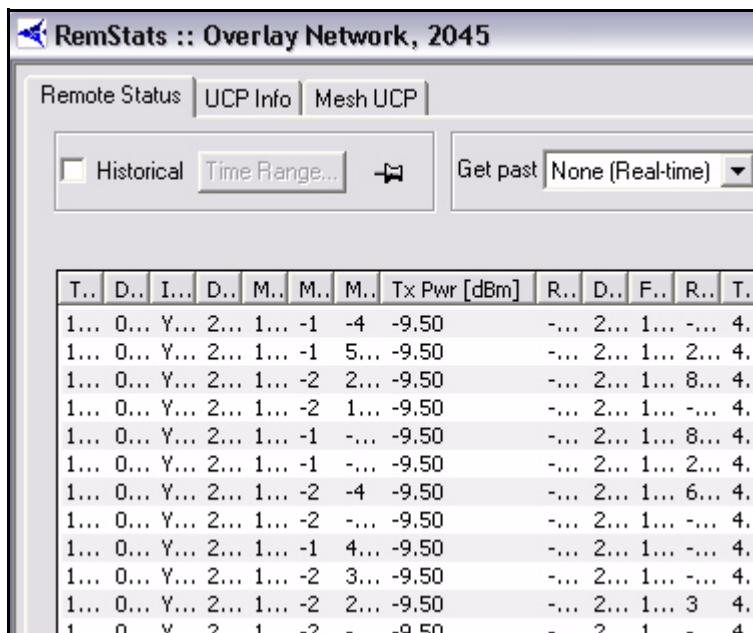

Figure 34. iMonitor Remote Status Dialog Box

6. Select the Remote Status tab.
7. Observe the column Tx Pwr [dBm].
8. Wait for the Tx Power to settle on a constant value and note the value.

Note: For a mesh remote, in clear sky conditions, if UCP adjusts the power up to the maximum power set in the 1dB compression test, and the signal strength is lower than the TDMA Clear Sky C/N, there may be a link budget problem. If the antenna is properly pointed and undamaged, then a larger dish or higher power BUC must be installed.

-
9. In iBuilder, right-click the remote in the network tree and select **Modify**→**Item** from the menu.
 10. Select the **Information** tab (Figure 31 on page 48).
 11. In the **Transmit Properties** section of the dialog box (Figure 35), enter the following value for **Initial Power**:
 - For star remotes, set **Initial Power** to 2 dB to 3 dB above the transmit power determined using iMonitor.
 - For mesh remotes, set **Initial Power** to the same setting as the transmit power determined using iMonitor.
 12. Click **OK** on the **Remote Information Tab** to save the changes.

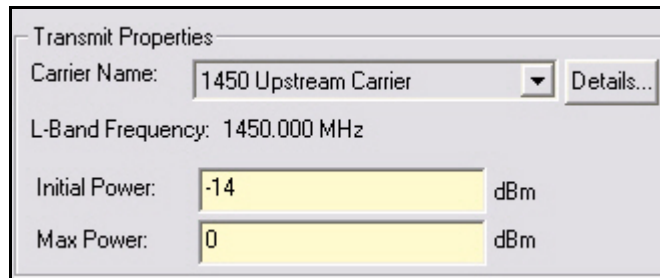

Figure 35. iBuilder Remote Information Tab: Transmit Properties Section

13. Right-click the remote in the network tree and apply the configuration by selecting **Apply Configuration**→**Reliable Both (TCP)**.
14. If you are commissioning a remote in a TRANSEC network:
 - If the remote has not yet been issued an X.509 certificate, issue the certificate at this time. (See the *iBuilder User Guide*, Appendix B, “Using the iDirect CA Foundry” for details.)
 - Re-enable authentication on the remote **Information** tab by clearing the **Disable Authentication** check box.
 - Click **OK** to save the changes.
 - Right-click the remote in the network tree and apply the configuration by selecting **Apply Configuration**→**Reliable Both (TCP)**.
15. Unless you are configuring a mesh remote, right-click the remote in the iBuilder network tree and select **Apply Configuration**→**Reliable Both (TCP)**. (For mesh remotes, proceed to the next section to set the clear sky C/N parameters before applying the configuration.)

13.3 Set the Clear Sky C/N Parameters for a Mesh Remote

If you are commissioning a mesh remote, follow these steps to set the values for SCPC Clear Sky C/N and for TDMA Loopback Clear Sky C/N. These parameters will help to diagnose issues related to fade during network operation.

1. In iMonitor, right-click the remote in the network tree and select Control Panel from the menu.

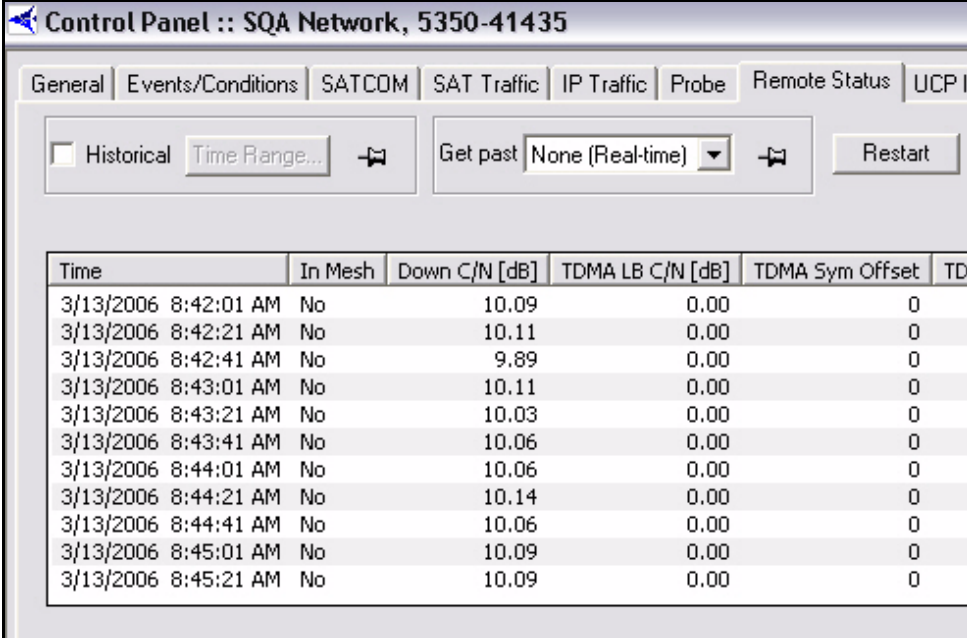

The screenshot shows the 'Control Panel' window for 'SQA Network, 5350-41435'. It features several tabs: General, Events/Conditions, SATCOM, SAT Traffic, IP Traffic, Probe, Remote Status, and UCP. Below the tabs are controls for 'Historical' data (checkbox), 'Time Range...' (button), 'Get past' (dropdown menu set to 'None (Real-time)'), and a 'Restart' button. A table displays performance metrics over time.

Time	In Mesh	Down C/N [dB]	TDMA LB C/N [dB]	TDMA Sym Offset	TDMA
3/13/2006 8:42:01 AM	No	10.09	0.00	0	
3/13/2006 8:42:21 AM	No	10.11	0.00	0	
3/13/2006 8:42:41 AM	No	9.89	0.00	0	
3/13/2006 8:43:01 AM	No	10.11	0.00	0	
3/13/2006 8:43:21 AM	No	10.03	0.00	0	
3/13/2006 8:43:41 AM	No	10.06	0.00	0	
3/13/2006 8:44:01 AM	No	10.06	0.00	0	
3/13/2006 8:44:21 AM	No	10.14	0.00	0	
3/13/2006 8:44:41 AM	No	10.06	0.00	0	
3/13/2006 8:45:01 AM	No	10.09	0.00	0	
3/13/2006 8:45:21 AM	No	10.09	0.00	0	

Figure 36. iMonitor Control Panel

2. Click the Remote Status tab and record the values for Down C/N [dB] and TDMA LB C/N [D/B].

3. In iBuilder, right-click the remote in the network tree and select Modify→Item from the menu to display the Remote dialog box.

The screenshot shows the 'Remote' configuration dialog box in iBuilder, with the 'Information' tab selected. The dialog has several fields and checkboxes:

- Name:** Remote 7350 41435
- Model Type:** 7350
- Serial Number:** 41435
- Derived ID (DID):** 6332891
- Inroute Group:** Tim G Mesh/Transec Inroute Group
- User Password:** iDirect
- Admin Password:** iDirect
- Active
- Link Encryption
- Sleep in 0 seconds
- TCP payload
- UDP header
- UDP payload
- CRTP
- MUSIC Box
- Disable Tx PWM
- Disable Authentication
- Mesh:**
 - Enabled
 - Home Inroute: None
 - SCPC Clear Sky C/N: 13 dB
 - TDMA LB Clear Sky C/N: 13 dB

Figure 37. iBuilder Remote Information Tab: Setting Clear Sky C/N

4. On the Information tab, ensure that Mesh Enabled is selected.
5. In SCPC Clear Sky C/N, enter the value recorded for Down C/N [dB] from iMonitor.
6. In TDMA Loopback Clear Sky C/N, enter the value recorded for TDMA LB C/N [dB] from iMonitor.
7. Click **OK** to save the changes.
8. Right-click the remote in the network tree and apply the configuration by selecting Apply Configuration→Reliable Both (TCP).



Appendix A Loading Images Using the TFTP Server

An alternate method of downloading the images to your Satellite Router is to use the TFTP server that comes bundled with iSite.

1. Open iSite and select TFTP from the File menu.
2. A pop up window will prompt you to select the TFTP server local folder. Browse and select the folder in which the remote package resides.
3. Open a console session to the Satellite Router and log on to the Linux prompt as root.
4. Enter `service idirect_falcon stop`. This will stop the iDirect application.
5. Enter `tftp_package.sh <IP address of TFTP server> <package name>`.
For example, if your laptop's IP address is 10.10.1.2 and you are loading 8.3.0.0 remote package the command will be `tftp_package.sh 10.10.1.2 remote 8_3_0_0.pkg`.
6. Once the transfer is complete, reset the remote using the `reboot` command.



Appendix B Pointing the Antenna Using Console Commands

This section describes the procedure for pointing the antenna using console commands and a digital voltmeter (DVM). This is an alternative method to that presented in [“Pointing the Antenna Using a Voltmeter”](#) on [page 25](#).

B.1 Performing Console Antenna Pointing

When using console pointing, the Rx and Tx cables from the Satellite Router can remain connected to the LNB and BUC, respectively.

Pin 8 on the RJ-45 connector *must* be pinned to pin 8 on the DB-9 connector to read DVM voltages from the serial port.

WARNING! *The following section must be completed to ensure that damage is not done to the BUC and that console pointing mode works correctly.*

B.2 Modifying the Options File to Disable the Transmit PWM Voltage

The options file *must* contain the line `options set ODU odu_disable_tx_pwm 1` with the value set to 1. Setting the value to 1 disables the transmit PWM voltage normally present on the transmit IFL cable.

The options file must be modified through the console port.

Note: *When the value is set to zero, DC voltage will be present on the transmit IFL cable at the BUC (Block Up-Converter) during the pointing process which could cause damage to the BUC and potentially generate an unwanted carrier.*

To modify the options file through the console port complete the following procedure.

1. Power on the Satellite Router and let it boot up completely.
2. From console or terminal session, enter the command:
`options set ODU odu_disable_tx_pwm 1`
3. Enter the command:
`options flash`
4. Reset the Satellite Router.

After the modem reboots, you must verify that the correct entry is in the options file.

1. Enter the command:

```
options show odu
```

2. In the ODU group, check to see that the line `odu_disable_tx_pwm = 1` is present. If this line is not present in the Options file, you must not start console pointing until it is present, or you will damage your hardware.

B.3 Starting the Console Pointing

To start the console pointing, enter the following commands.

1. Enter the command:

```
rx pointing enable
```

2. Enter the command:

```
rx pointing on
```

At this point, the Satellite Router is in console pointing mode.

B.4 Using the DVM for Console Pointing

To use the digital voltmeter for console pointing, complete the following steps.

1. Disconnect the console port from the laptop, leaving the RJ-45 connector connected to the Satellite Router.
2. From the DB-9 connector, connect pin 4 or 5 (GND) to the negative probe on the DVM.
3. Connect pin 8 (+) to the positive probe on the DVM.
4. Point the antenna using the normal procedure, until the signal falls into the desired range ([Table 5](#)).

Table 5. Signal Strength Ranges (DVM)

Signal Strength Ranges	
Volts DC	Antenna Status
0-2.5 VDC	RF energy is detected, but from the wrong satellite
2.6 - 5.0 VDC	Carrier lock, correct satellite

Note: *The LEDs the front panel of the Satellite Router will verify Carrier Lock. See [Table 3](#) on page 42 [Table 4](#) on on page 43 and for details on remote LED status indicators.*

To point the antenna:

1. Slowly sweep the reflector in azimuth until a signal of the appropriate strength is found.
2. If the desired signal is not found, increase or decrease elevation setting by 2° and repeat the azimuth sweep.
3. When you have found the desired signal, tighten down the 4 bolts on the Yoke Cap that secure the Yoke Cap to the Mast Pipe.

B.5 Final Adjustments

The remaining azimuth adjustments are made with the azimuth adjustment screws.

1. Ensure Top Plate locking bolts are snug to allow azimuth movement.
2. Adjust the elevation until maximum DC voltage is obtained.
3. Fine tune azimuth until maximum DC voltage is obtained.
4. Make sure azimuth and elevation are locked down.
5. Adjust polarization until maximum DC voltage is obtained.
6. Write down the final antenna pointing voltage reading and give the reading to the operator at the Network Help Desk.
7. When finished pointing, disconnect power from the Satellite Router to stop the pointing process.



Appendix C Disabling the PWM Voltage in iBuilder

If you have access to iBuilder, you can verify that the transmit PWM voltage normally present on the transmit IFL cable is disabled.

To verify the transmit PWM voltage normally present on the transmit IFL cable is disabled through iBuilder perform the following steps.

1. Power up the Satellite Router and let it boot up completely.
2. In iBuilder, right-click the remote and select Modify→Item.

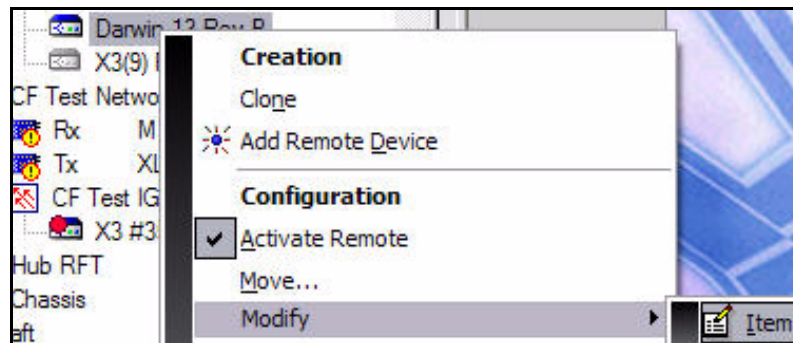

The Remote Information tab will display.

The screenshot shows the 'Remote' tab in the iBuilder interface. The tab is titled 'Remote' and contains the following fields and options:

- Name: Darwin 31 revb
- Model Type: X3
- Serial Number: 31
- Derived ID (DID): 33554463
- Inroute Group: Inroute
- User Password: iDirect
- Admin Password: iDirect
- Active:
- MUSiC Box:
- Link Encryption:
- Disable Tx PWM: (A mouse cursor is pointing at this checkbox.)
- Sleep in: 0 seconds

Figure 38. iBuilder Remote Information Tab: Disabling Tx PWM

3. On the Remote Information tab, select Disable Tx PWM if it is not already selected.
4. Reset the Satellite Router.

Appendix D Pinout for RJ-45 to DB-9 Adapter

In addition to the Satellite Router console cable, you will need an RJ-45 to DB-9 adapter. The pinouts are as follows:

Table 6. DB-9 to RJ-45 Adapter Pinout

DB-9 to RJ-45 Adapter Pin-Out		
RJ-45	Color Code	DB-9
1	Blue	8
2	Orange	6
3	Black	2
4	Red	5
5	Green	N.C.
6	Yellow	3
7	Brown	4
8	White/Gray	7

iDirect, Inc.

13865 Sunrise Valley Drive

Herndon, VA 20171

+1 703.648.8000

+1 866.345.0983

www.idirect.net

Advancing a Connected World